

MS50

HYDRAULIC MOTORS

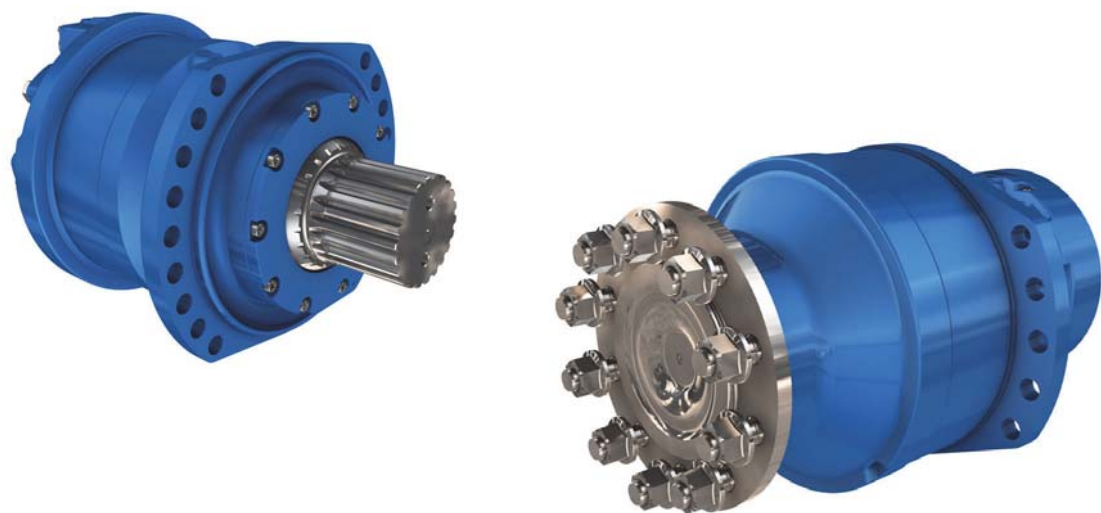

T E C H N I C A L C A T A L O G



CHARACTERISTICS

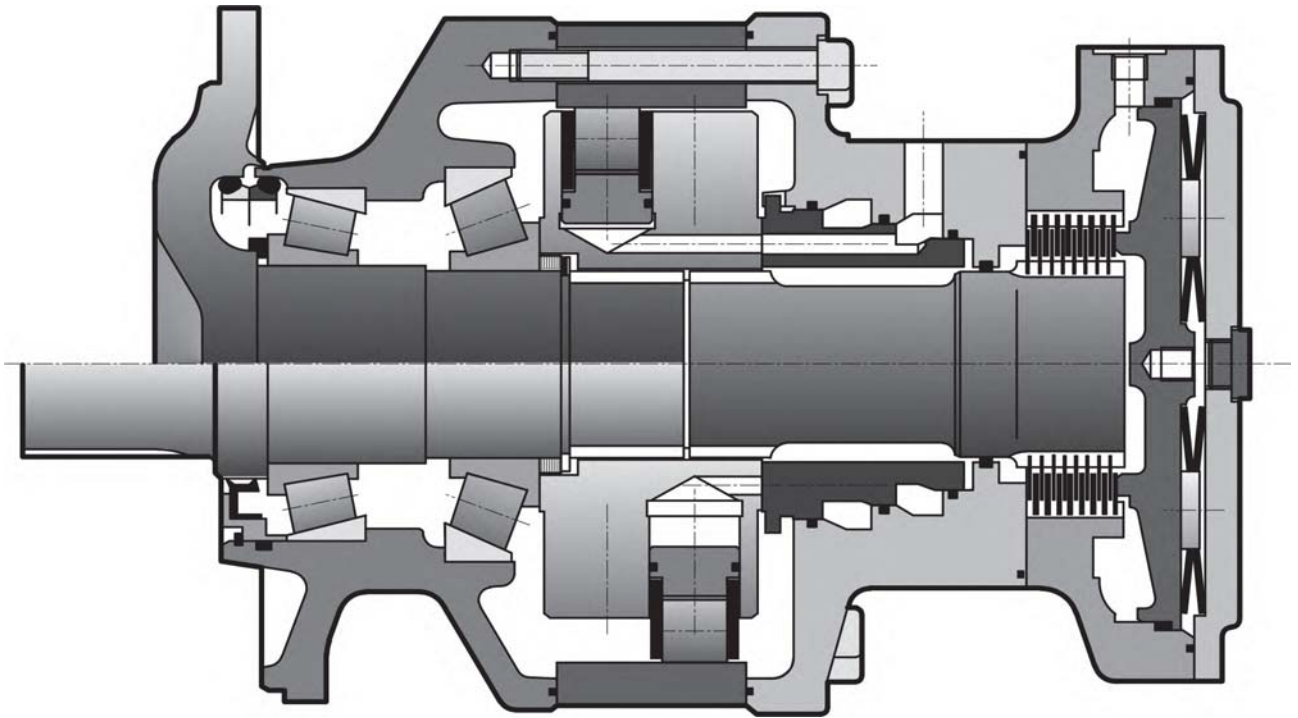

Motor inertia 1 kg.m²

C	Displacement		Theoretical torque		Max. power			Max. speed		Max. pressure
	1	2	1	2	1	2	2	1	2	
	cm ³ /tr [cu.in/rev.]	cm ³ /tr [cu.in/rev.]	at 100 bar Nm	at 1000 PSI [lb.ft]	kW [HP]	preferred kW [HP]	non-preferred kW [HP]	tr/min [RPM]		bar [PSI]
Cams with equal lobes	7	3 500 [213,5]	1 750 [106,7]	5 565 [2 830]	140 [188]	93 [125]	70 [94]	148	148	450 [6 527]
	8	4 008 [244,4]	2 004 [122,2]	6 373 [3 241]				138	145	
	9	4 498 [274,3]	2 249 [137,2]	7 152 [3 637]				124	141	
	0	4 997 [304,8]	2 499 [152,4]	7 945 [4 040]				111	127	
	1	5 504 [335,7]	2 752 [167,8]	8 751 [4 450]				101	116	
	2	6 011 [366,6]	3 006 [183,3]	9 557 [4 860]				92	114	
Cams with unequal lobes	K	4 252 [259,3]	2 752 [167,8]	6 761 [3 438]	140 [188]	93 [125]	70 [94]	116		450 [6 527]
			1 500 [91,5]					172		
	A	5 010 [305,6]	3 006 [183,3]	7 966 [4 051]				114		
			2 004 [122,2]					145		

- 1 First displacement
- 2 Second displacement

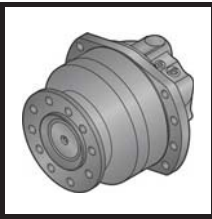
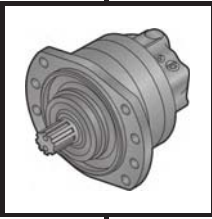
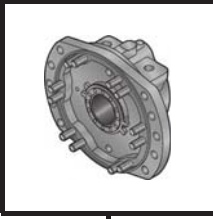
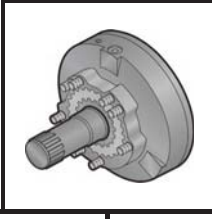
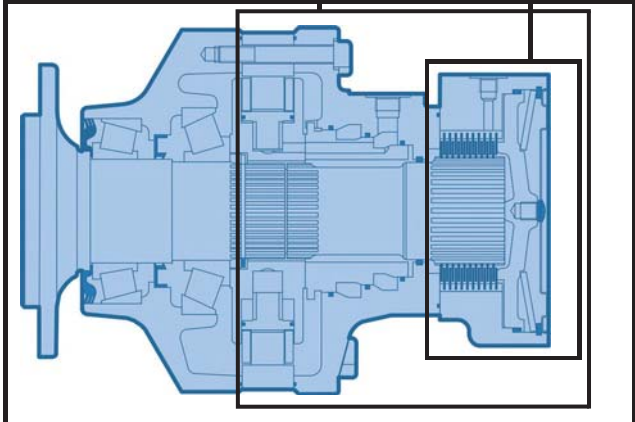

CONTENT

	MODULARITY	4	Modularity and Model code
	MODEL CODE	6	
	WHEEL MOTOR	8	Wheel motor
	Dimensions for standard (1110) 1-displacement motor	8	
	Dimensions for standard (1110) 2-displacement motor	9	
	Dimensions for standard (1110) Twin-Lock™ motor	9	
	Studs	10	
	Load curves	11	
	SHAFT MOTOR	13	Shaft motor
	Dimensions for standard (2A50) 1-displacement motor	13	
	Dimensions for standard (2A50) 2-displacement motor	13	
	Support types	14	
	Splined coupling	14	
	Cylindrical bushed coupling	15	
	Load curves	15	
	VALVING SYSTEMS AND HYDROBASES	17	Valving systems and hydrobases
	Dimensions for 1-displacement valving	17	
	Cylinder block splines	17	
	Dimensions for other valving systems	18	
	Chassis mountings	20	
	Hydraulic connections	21	
	Efficiency	22	
	BRAKES	23	Brake
	Rear brake	23	
	Rear brake	24	
	Drum brake (432 x 102)	25	
	OPTIONS	27	Options



MODUL

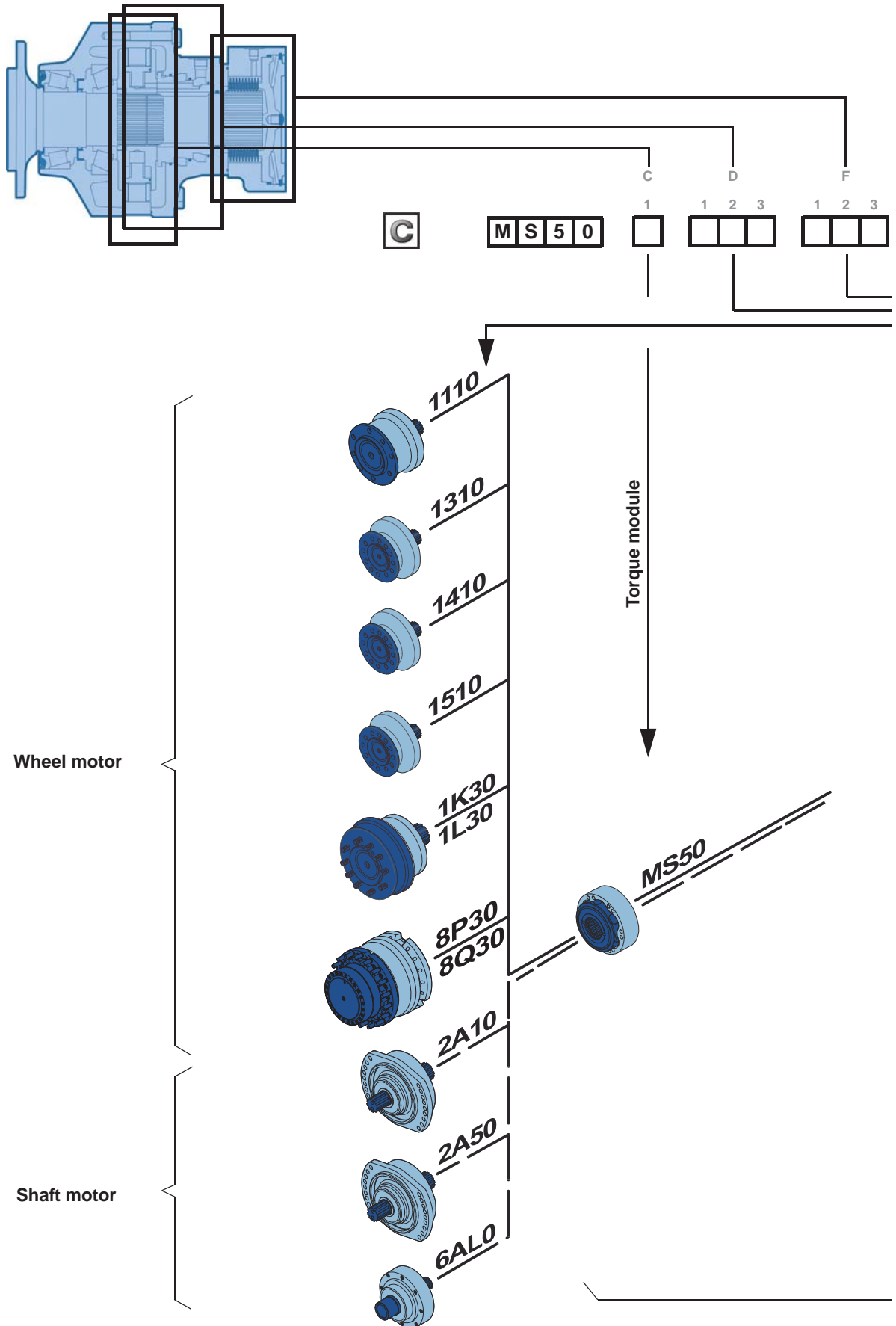



MODULARITY

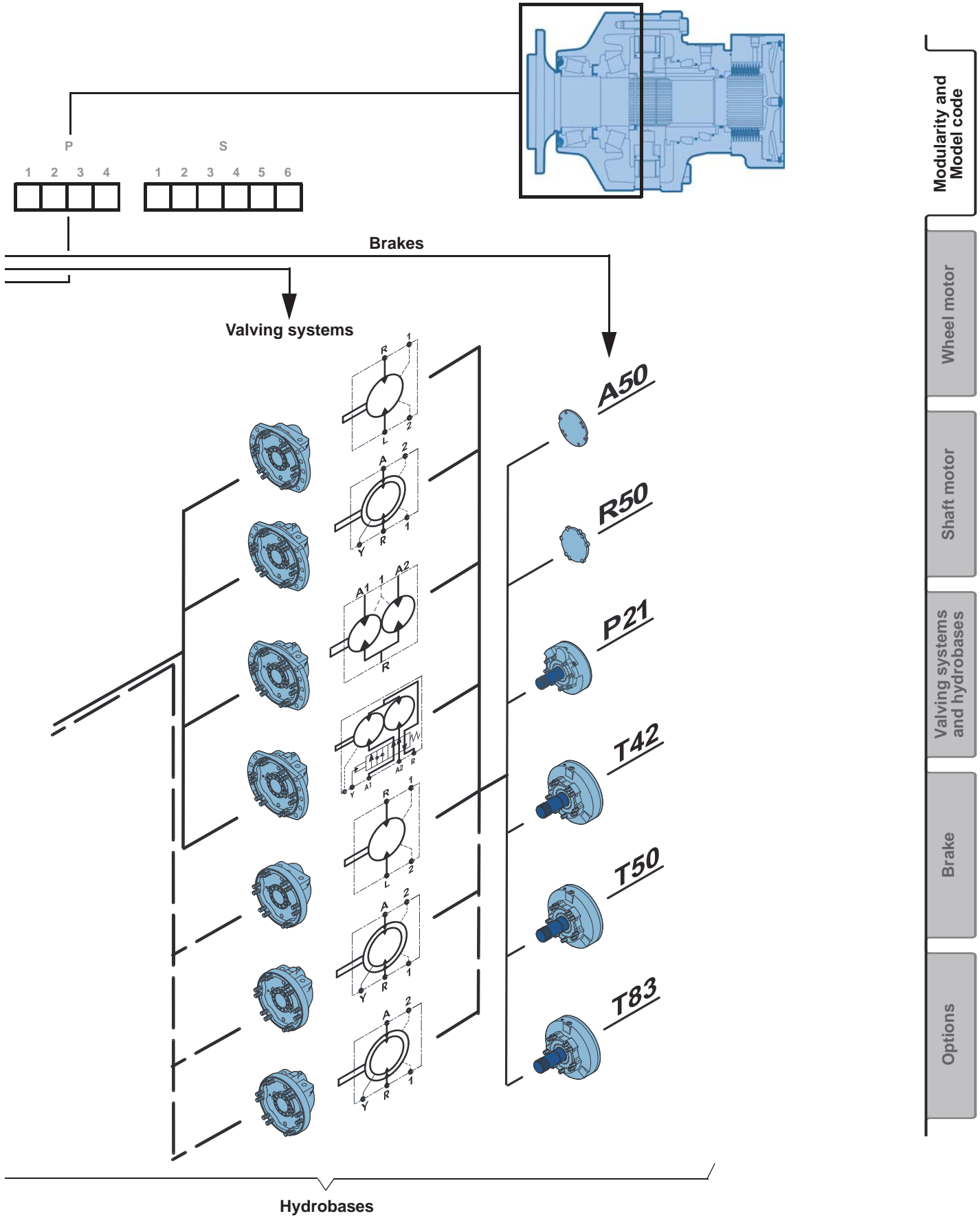



MODEL

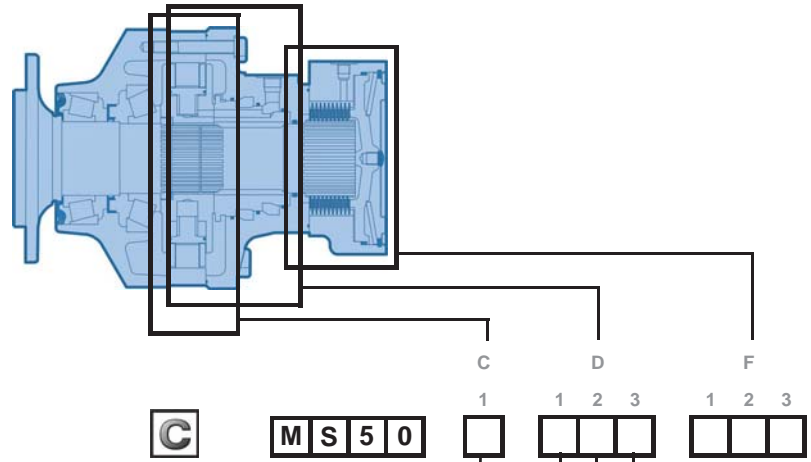

	①		②	
	cm³/tr [cu.in/rev.]	cm³/tr [cu.in/rev.]	cm³/tr [cu.in/rev.]	cm³/tr [cu.in/rev.]
Cams with equal lobes	7	3 500 [213,5]	1 750 [106,7]	
	8	4 008 [244,4]	2 004 [122,2]	
	9	4 498 [274,3]	2 249 [137,2]	
	0	4 997 [304,8]	2 499 [152,4]	
	1	5 504 [335,7]	2 752 [167,8]	
	2	6 011 [366,6]	3 006 [183,3]	
Cams with unequal lobes	K	4 252 [259,3]	2 752 [167,8]	
			1 500 [91,5]	
	A	5 010 [305,6]	3 006 [183,3]	
			2 004 [122,2]	

Without mounting	1	1	D	K
Lug fixing	2	2	E	V
	1-displacement	2-displacement	Twin-Lock™	Twin-Lock™ or 2-displacement

Without cover	0
ISO 6162 DN 25 SAE flanges ISO 9974-1 metric connections	1
ISO 6162 DN 32 SAE flanges ISO 9974-1 metric connections	6
ISO 6162 DN 25 SAE flanges ISO 11926-1 connections	7

① First displacement
② Dual displacement

1-displacement valving	1
2-displacement valving (No special direction)	A Ratio 2
	B Ratio <2
	C Ratio >2
2-displacement & Twin-Lock™ valving (Clockwise)	D Ratio 2
	E Ratio <2 F Ratio >2
2-displacement & Twin-Lock™ valving (Counterclockwise)	G Ratio 2
	H Ratio <2 J Ratio >2

Without brake	Simple plate	A 5 0
	Reinforced plate	R 5 0
	Clipped environmental cover	P 2 1
Brakes	Screwed environmental cover	T 4 2
		T 5 0
		T 8 3



CODE

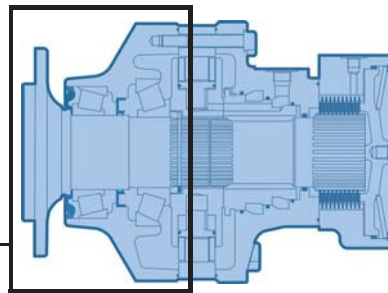

0	Without bearing support
1	Without mounting
2	Lug mounting
6	Motor torque
8	Fixation on the spindle

Without shaft	0
12 x Ø26 on Ø425	1
10 x Ø24 on Ø335	3
10 x Ø24 on Ø335	4
12 x Ø22 on Ø275	5

10 studs on Ø335	Mineral	K
Drum brake	DOT	L
18 studs on Ø440	Mineral	P
	DOT	Q
Bearing support for shaft		A

Plate

Without studs	1
With studs + nuts	2
With studs	3

Male shafts

NF E 22 141 splines	1
DIN 5480 splines	5
Bushed female (motor torque)	L

Drum brake

Without drum brake	0
Without cable	4
Right-hand cable outlet	5
Left-hand cable outlet	6

Without Options or Adaptations	0
Fluorinated elastomer seals	1
T4 Speed sensor installed	2
Drainage	5
Industrial bearing support	6
Diamond™	7
Predisposition for speed sensor	8
Double-centering valving cover	9
Hollow shaft	A
Drain on the bearing support	B
Hostile environment	C
Reinforced sealing	E
Special wheel rim mounting	G
Surface heat treatment of the shaft	J
TR Speed sensor installed	S
For vertical mounting (shaft upward)	N

Modularity and Model code

Wheel motor

Shaft motor

Valving systems and hydrobases

Brake

Options



Methodology :

This document is intended for manufacturers of machines that incorporate Poclair Hydraulics products. It describes the technical characteristics of Poclair Hydraulics products and specifies installation conditions that will ensure optimum operation. This document includes important comments concerning safety. They are indicated in the following way:



Safety comment.

This document also includes essential operating instructions for the product and general information. These are indicated in the following way:



Essential instructions.



General information .



Information on the model number.Information on the model code.



Weight of component without oil.



Volume of oil.



Units.



Tightening torque.



Screws.



Information intended for Poclair-Hydraulics personnel.

The views in this document are created using metric standards.

The dimensional data is given in mm and in inches (inches are between brackets and italic>



Dimensions for standard (1110) 1-displacement motor

	310 kg [682 lb]	415 kg [913 lb]
	6,00 L [360 cu.in]	4,50 L [270 cu.in]

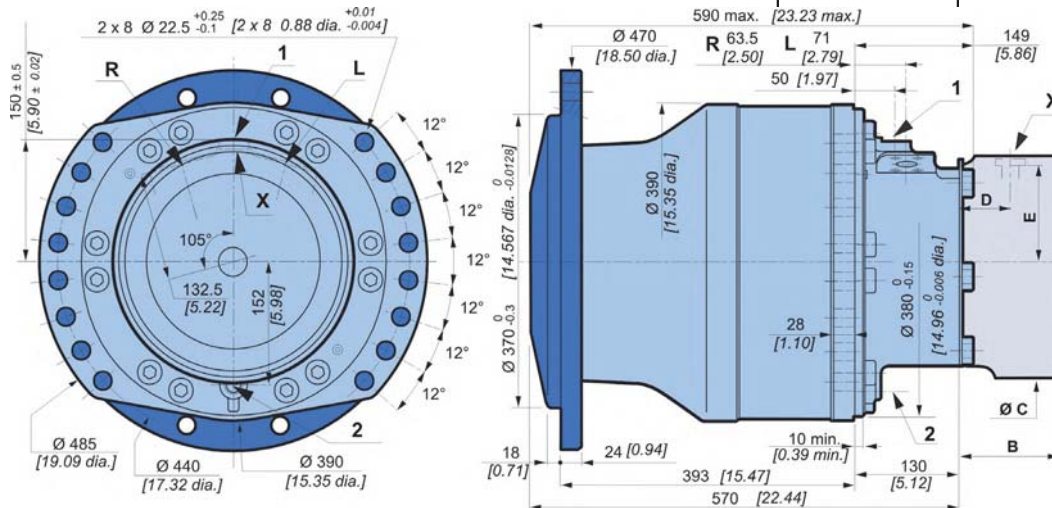
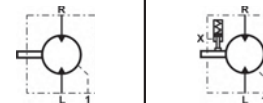



WHEEL MOTOR

Dimensions for standard (1110) 2-displacement motor

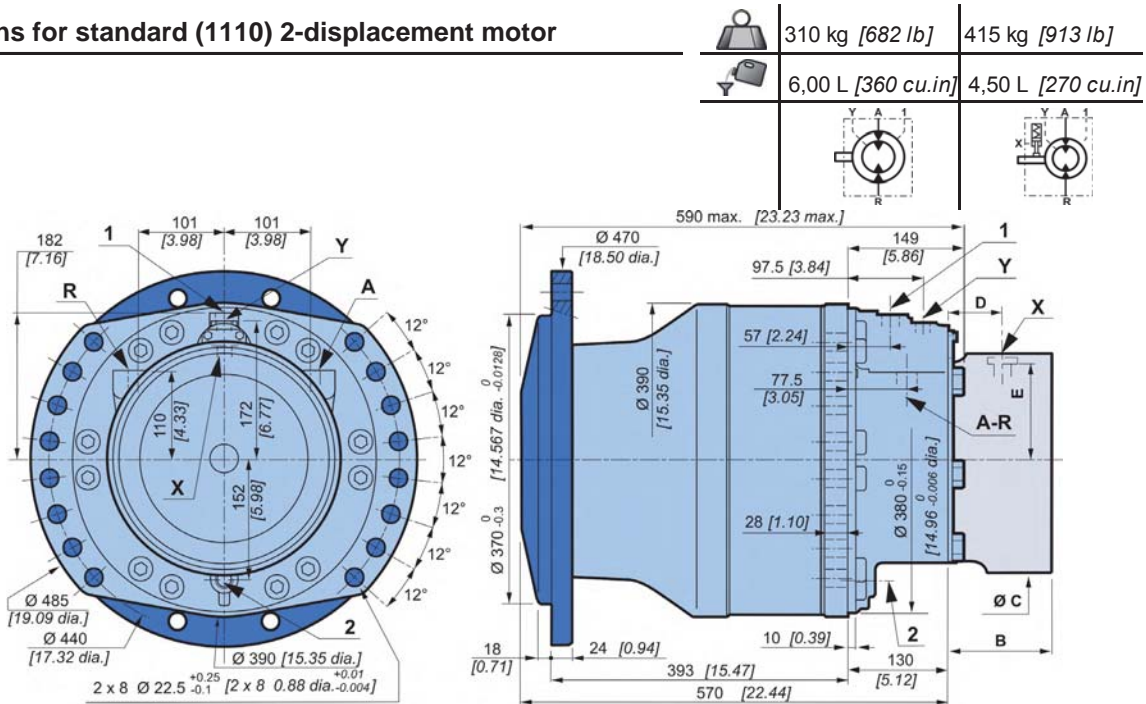

	310 kg [682 lb]	415 kg [913 lb]
	6,00 L [360 cu.in.]	4,50 L [270 cu.in.]



Modularity and Model code

Wheel motor

Shaft motor

Dimensions for standard (1110) Twin-Lock™ motor

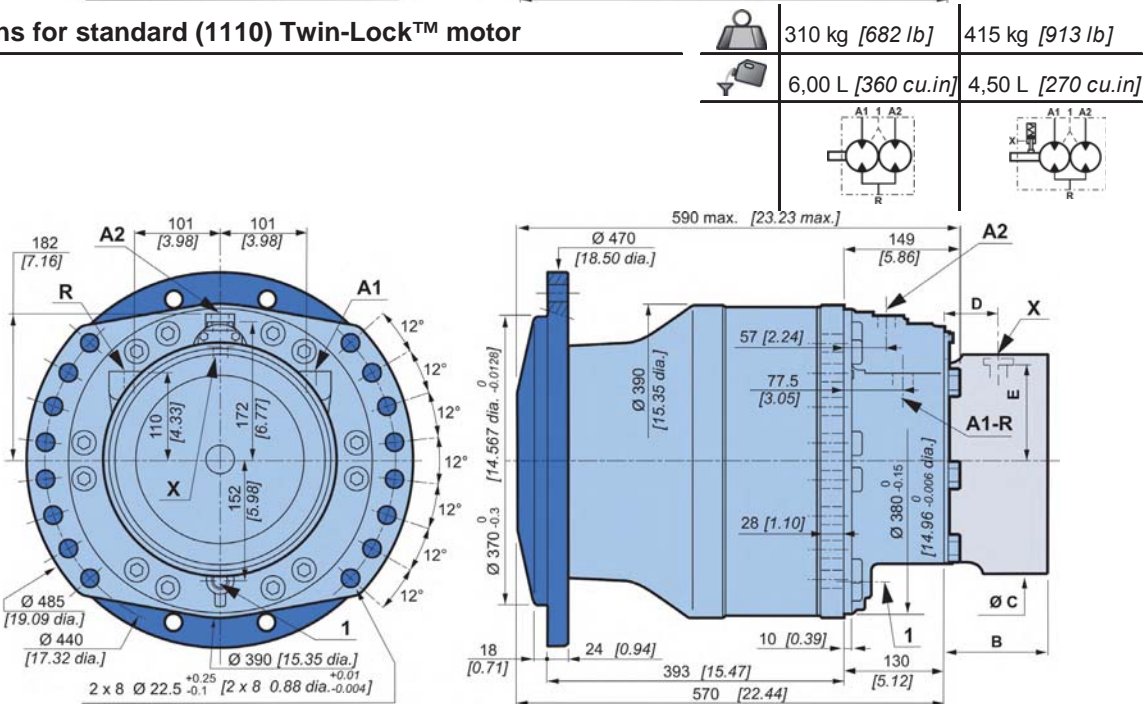

	310 kg [682 lb]	415 kg [913 lb]
	6,00 L [360 cu.in.]	4,50 L [270 cu.in.]



Valving systems and hydrobases

Brake

Options



Also see 'Valving systems and hydrobases' section (thumbnail opposite).

	C	P 2 1	T 4 2	T 5 0	T 8 3
B	108,5 [4,27]	148,0 [5,83]	157,5 [6,20]	159,0 [6,26]	
C	Ø280 [11,02 dia.]	Ø375 [14,76 dia.]	Ø375 [14,76 dia.]	Ø375 [14,76 dia.]	
D	57 [2,24]	63,5 [2,50]	63,5 [2,50]	63,5 [2,50]	
E	138,5 [5,45]	183,5 [7,22]	183,5 [7,22]	183,5 [7,22]	



Also see "Brake" section (thumbnail opposite).



Support types

	C				D			F			P				S						
	1	1	2	3	1	2	3	1	2	3	1	2	3	4	1	2	3	4	5	6	
M S 5 0																					
	A	B	C	D	E	N	Wheel rim mountings	L													
	mm [in]	mm [in]	mm [in]	mm [in]	mm [in]	mm [in]		mm [in]													
1 1 1 0 1 2 3 4 P	Ø 370 [14,57 dia.]	Ø 425 [16,73 dia.]	Ø 472 [18,58 dia.]	393 [15,47]	Ø 390 [15,35 dia.]	Ø 26 [1,02 dia.]	12 x M24x2	24 [0,94]													
1 3 1 0 1 2 3 4 P	Ø 280,7 [11,05 dia.]	Ø 335 [13,19 dia.]	Ø 379 [14,92 dia.]	335 [13,19]	Ø 390 [15,35 dia.]	Ø 24 [0,94 dia.]	10 x M22x1.5	17 [0,67]													
1 4 1 0 1 2 3 4 P	Ø 280,7 [11,05 dia.]	Ø 335 [13,19 dia.]	Ø 379 [14,92 dia.]	296 [11,65]	Ø 390 [15,35 dia.]	10 x Ø 24 [10 x 0,94 dia.]	-	17 [0,67]													
1 5 1 0 1 2 3 4 P	Ø 220,7 [8,69 dia.]	Ø 275 [10,83 dia.]	Ø 314,5 [12,38 dia.]	348 [13,70]	Ø 390 [15,35 dia.]	(8+4) x Ø 22 [0,87 dia.]	-	18 [0,71]													
1 K 2 0 1 L 2 0 1 2 3 4 P	Ø 280,7 [11,05 dia.]	Ø 335 [13,19 dia.]	Ø 482 [18,98 dia.]	396 [15,59]			10 x M22x1.5	45 [1,77]													
Also see "Brake" section (thumbnail opposite).																					
8 P 3 0 8 Q 3 0 1 2 3 4 P	Ø 390,0 [15,35 dia.]	Ø 440 [17,32 dia.]	Ø 483,5 [19,04 dia.]	314 [12,36]			18 x M22x1.5	80 [3,15]													
Also see "Brake" section (thumbnail opposite).																					

Studs

		P	C min.	C max.	D	Class		(1) *		(2) *
		mm [in]	mm [in]	mm [in]	mm [in]					
Various studs	M22 x 1.5	80 [3,15]	5 [0,20]	36 [1,42]	26 [1,02]	 P D C	12,9	695 [512,6]	1 050 [774,4]	(3)
	M24 x 2	95 [3,74]		38 [1,50]	30 [1,18]					
Screws	M20	-	-	-	-	12,9	600 [442,5]	770 [567,9]		

(* The tightening torques are given for the indicated loads.

(1) Wheel rim : Suggested tightening torque for wheel rim mountings (Re steel disc > 240 N/mm² [>34 800 PSI]).

(2) Standard : Suggested tightening torque in other cases (Re steel flange 360 > N/mm² [>52 215 PSI]).

(3) In case of bearings 8P30 and 8Q30 : Poclair recommends to use the flanged nuts with tightening torque = 900 Nm



See generic installation motors N°801478197L.



Load curves

Permissible radial loads

Test conditions :

Static : 0 tr/min [0 RPM] 0 bar [0 PSI]

Dynamic : 0 tr/min [0 RPM], code 0 displacement, without axial load at max. torque

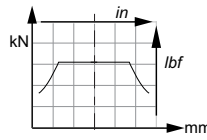

Service life of bearings

Test conditions :

L : Millions B10 revolutions at 150 bars (average pressure), with 25 cSt fluid, code 0 displacement, without axial load.

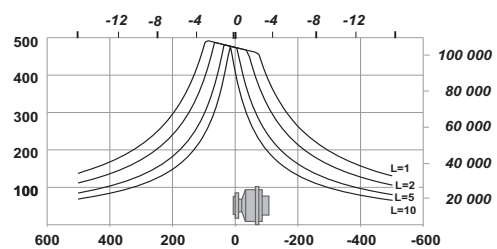
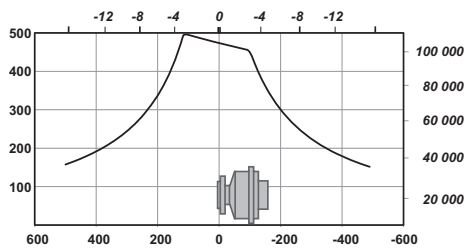
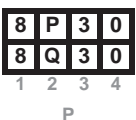
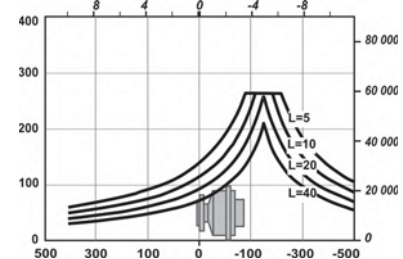
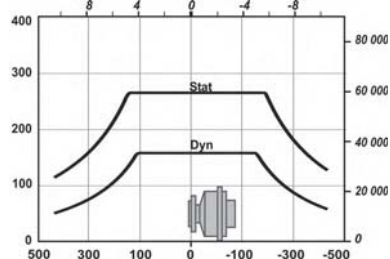
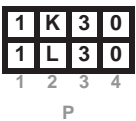
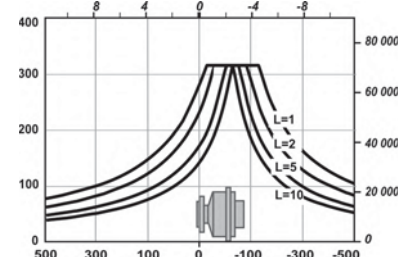
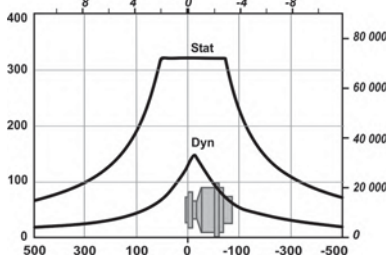
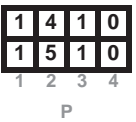
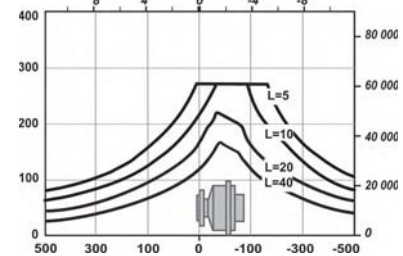
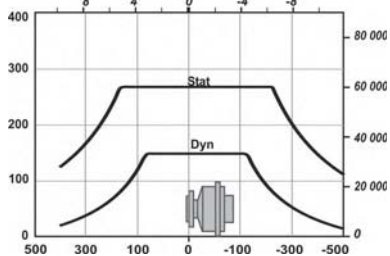
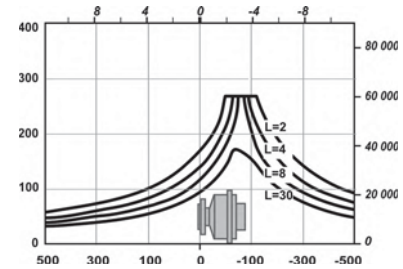
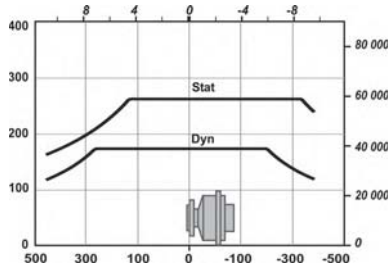

Modularity and Model code

Wheel motor

Shaft motor

Valving systems and hydrobases

Brake

Options



The service life of the components is influenced by the pressure. You must check that the combination of forces applied (Axial load / Radial load) is compatible with the permissible loads for the components, and that the resulting service lives of these components complies with the application's specifications. For an accurate calculation, consult your Poclair Hydraulics application engineer.

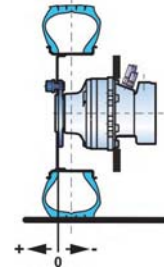



SHAFT MOTOR

Dimensions for standard (2A50) 1-displacement motor

	265 kg [583 lb]	370 kg [814 lb]
	6,00 L [360 cu.in]	4,50 L [270 cu.in]

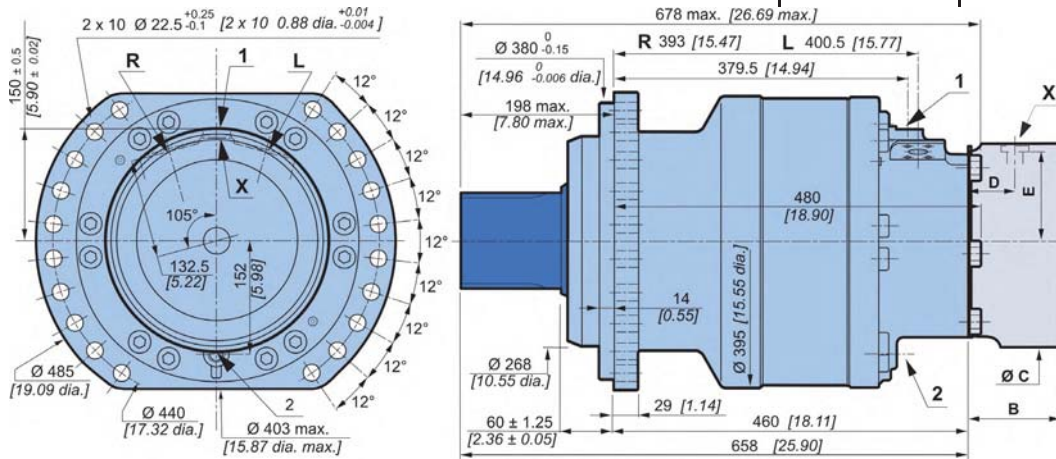

Dimensions for standard (2A50) 2-displacement motor

	265 kg [583 lb]	370 kg [814 lb]
	6,00 L [360 cu.in]	4,50 L [270 cu.in]

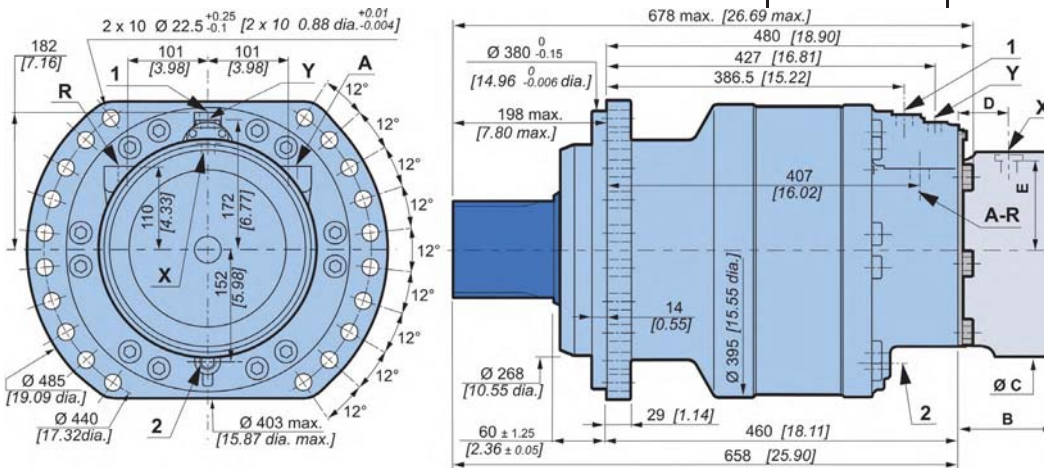

Also see 'Valving systems and hydrobases' section (thumbnail opposite).

	C	P 2 1	T 4 2	T 5 0	T 8 3
B	108,5 [4,27]	148,0 [5,83]	157,5 [6,20]	159,0 [6,26]	
C	Ø280 [11,02 dia.]	Ø375 [14,76 dia.]	Ø375 [14,76 dia.]	Ø375 [14,76 dia.]	
D	57 [2,24]	63,5 [2,50]	63,5 [2,50]	63,5 [2,50]	
E	138,5 [5,45]	183,5 [7,22]	183,5 [7,22]	183,5 [7,22]	

Also see "Brake" section (thumbnail opposite).

- Modularity and Model code
- Wheel motor
- Shaft motor
- Valving systems and hydrobases
- Brake
- Options



Support types

				C			D			F			P				S										
				1	2	3	1	2	3	1	2	3	1	2	3	4	1	2	3	4	5	6					
M S 5 0																											
C							A			B			C			D			E			F					
				mm [in]			mm [in]			mm [in]			mm [in]			mm [in]			mm [in]			mm [in]					
DIN 5480 splines																											
2 A 5 0				Nominal Ø			130 [5,12]			40			R 4			60			2 x M16			32			136		
1 2 3 4				Module			5			[1,57]			[R 0,16]			[2,36]			[1,26]			[5,35]					
P				Z			24																				
NF E22-141 splines																											
2 A 1 0				Nominal Ø			130 [5,12]			40			R 4			60			2 x M16			32			136		
1 2 3 4				Module			3,75			[1,57]			[R 0,16]			[2,36]			[1,26]			[5,35]					
P				Z			33																				
6 A L 0				Ø 115			Ø 155			170			388			Ø 249			Ø 340								
1 2 3 4				[4,53 dia.]			[6,10 dia.]			[6,69]			[15,28]			[9,80 dia.]			[13,39 dia.]								
P																											

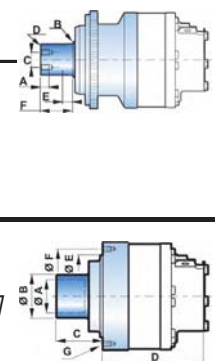

i Also see 'Valving systems and hydrobases' section (thumbnail opposite).

Splined coupling

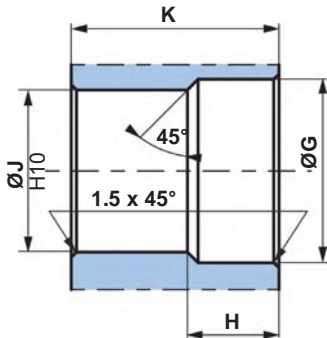

N : Nominal Ø.
Mo : Module.
Z : Number of teeth.

Standard DIN 5480
 Pressure angle 30°.
 Centering on flanks.
 Slide fit (7H quality).

Standard NF E 22-141
 Pressure angle 20°.
 Centering on flanks.
 Slide fit (7H quality).

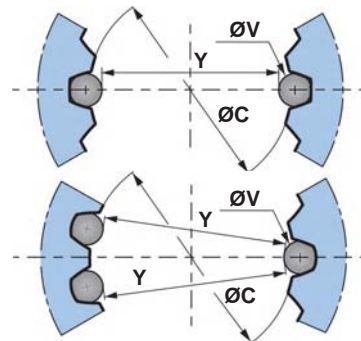

				Ø G	H	Ø J	K	N	Mo	Z	Offset	(H10)	Ø V	Y	Tolerance
				mm [in]	mm [in]	mm [in]	mm [in]	mm [in]			mm [in]	mm [in]	mm [in]	mm [in]	µm [µin]
2 A 5 0				132	33	120	135	130	5	24	2,25	120	9	111,104	+ 87 / 0
1 2 3 4				[5,20]	[1,30]	[4,72]	[5,31]	[5,12]			[0,09]	[4,72]	[0,35]	[4,37]	[+3.425 / 0]
P															
2 A 1 0				131	33	122,5	135	130	3,75	33	2,373	122,5	7,5	115,081	+ 113 / 0
1 2 3 4				[5,16]	[1,30]	[4,82]	[5,31]	[5,12]			[0,0934]	[4,82]	[0,30]	[4,53]	[+4.448 / 0]
P															

General tolerances : ± 0.25 [±0.0098].

Material: Ex: 42CrMo4.

Hardening treatment to obtain R = 800 to 900 N/mm² [R = 116 030 to 130 533 PS].



Cylindrical bushed coupling

C				A	B	C	D
				mm [in]	mm [in]	mm [in]	mm [in]
6	A	L	0	∅ 115 [4,53 dia.]	105 [4,13]	10 [0,394]	0,5 [0,0197]
1	2	3	4				

$R_{min.} : 640 \text{ N/mm}^2 [132\ 800 \text{ PSI}]$

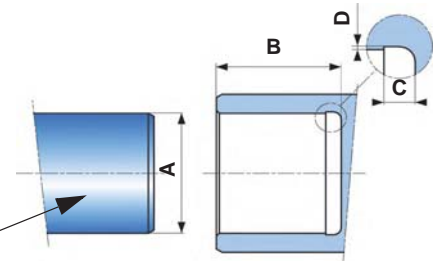

Load curves

Permissible radial loads

Max. permissible loads: 0 tr/min [0 RPM]; 0 bar [0 PSI]

Continuous permissible loads:
> 0 tr/min [> 0 RPM]; 275 bar [3 988 PSI].

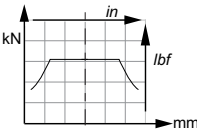

Service life of bearings

Test conditions :

L : Millions B10 revolutions at 150 bars (average pressure), with 25 cSt fluid, code 0 displacement, without axial load.

2	A	5	0
2	A	1	0
1	2	3	4

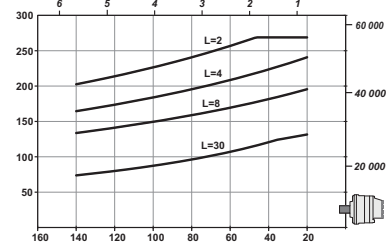
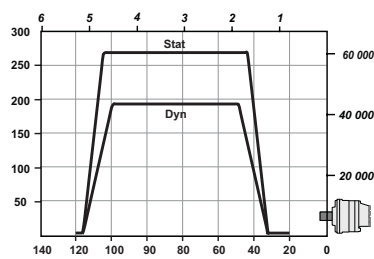

6	A	L	0
1	2	3	4

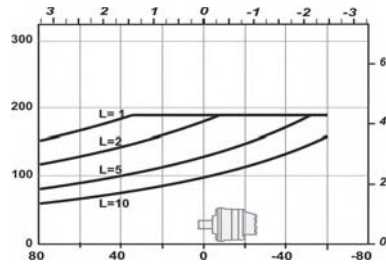
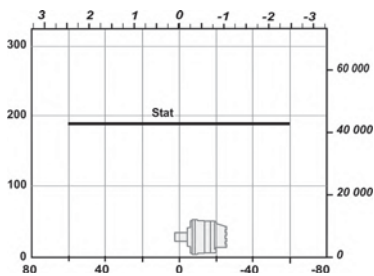

The service life of the components is influenced by the pressure. You must check that the combination of forces applied (Axial load / Radial load) is compatible with the permissible loads for the components, and that the resulting service lives of these components complies with the application's specifications. For an accurate calculation, consult your Poclain Hydraulics application engineer.

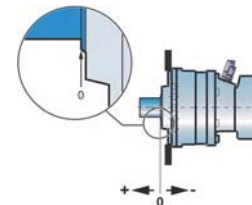

Modularity and Model code

Wheel motor

Shaft motor

Valving systems and hydrobases

Brake

Options





VALVING SYSTEMS AND HYDROBASES

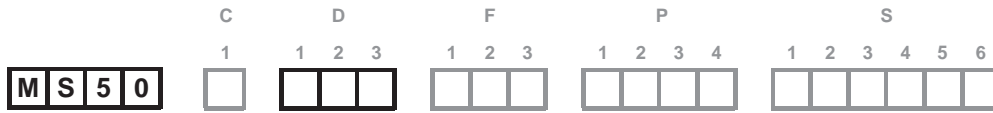

Dimensions for 1-displacement valving

	145 kg [318 lb]	230 kg [505 lb]
	2,20 L [132 cu.in]	2,50 L [150 cu.in]

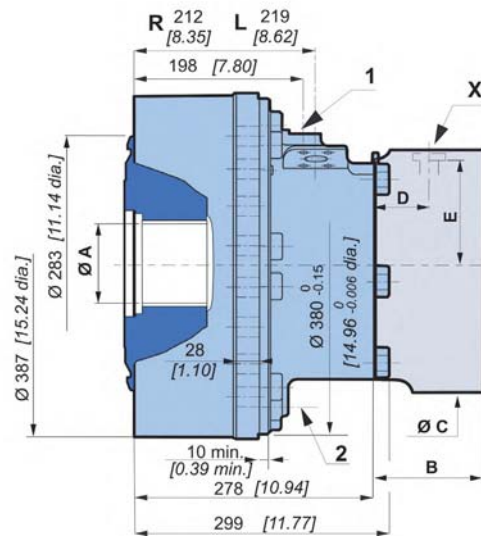
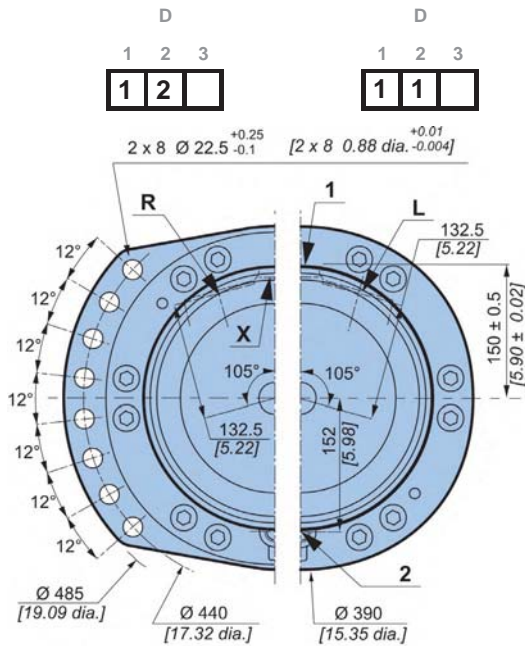

	C	P 2 1	T 4 2	T 5 0	T 8 3
B	108,5 [4,27]	148,0 [5,83]	157,5 [6,20]	159,0 [6,26]	
C	Ø280 [11,02 dia.]	Ø375 [14,76 dia.]	Ø375 [14,76 dia.]	Ø375 [14,76 dia.]	
D	57 [2,24]	63,5 [2,50]	63,5 [2,50]	63,5 [2,50]	
E	138,5 [5,45]	183,5 [7,22]	183,5 [7,22]	183,5 [7,22]	

Also see "Brake" section (thumbnail opposite).

Cylinder block splines

(as per standard NF E22-141)

ØA	Module	Z	Dimension on 2 pins	
			Y	ØV
100 [3,937]	2,5	38	90,169 [3,550]	5 [0,197]

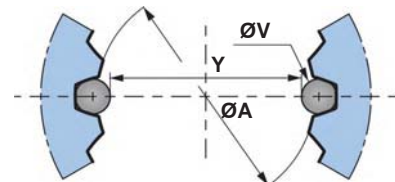

You are advised to have the installation validated by your Poclair Hydraulics application engineer before using the hydraulic unit in an application.



We must provide you with a detailed plan of the interface for any hydraulic unit use, consult your Poclair Hydraulics sales engineer.

Modularity and Model code

Wheel motor

Shaft motor

Valving systems and hydrobases

Brake

Options



Dimensions for 2-displacement valving

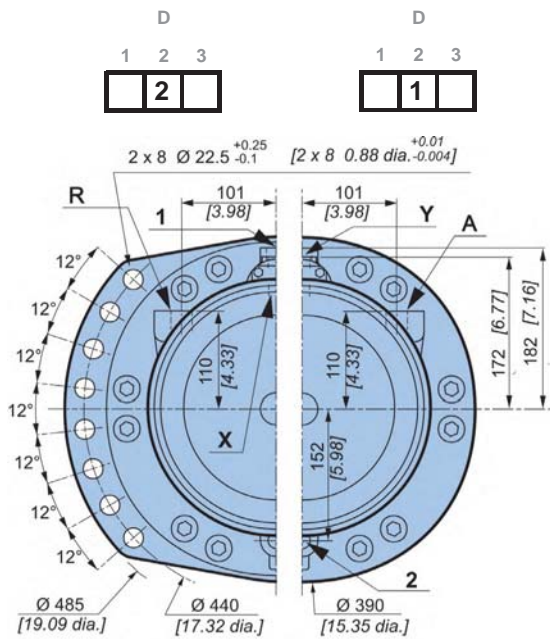

	160 kg [352 lb]	246 kg [541 lb]
	2,20 L [132 cu.in]	2,50 L [150 cu.in]

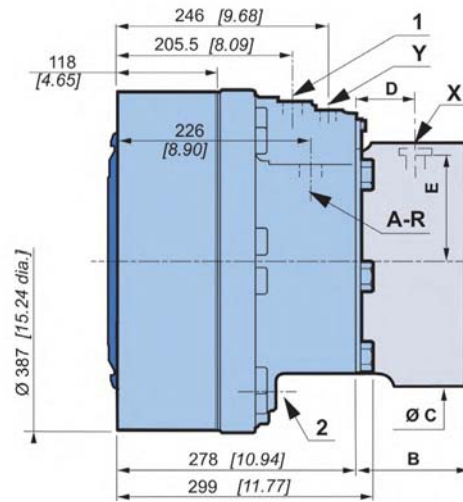

Dimensions for 2-displacement symmetrical valving

For a small displacement, there is no preferred orientation for this motor.

	173 kg [380 lb]	258 kg [568 lb]
	2,20 L [132 cu.in]	2,50 L [150 cu.in]

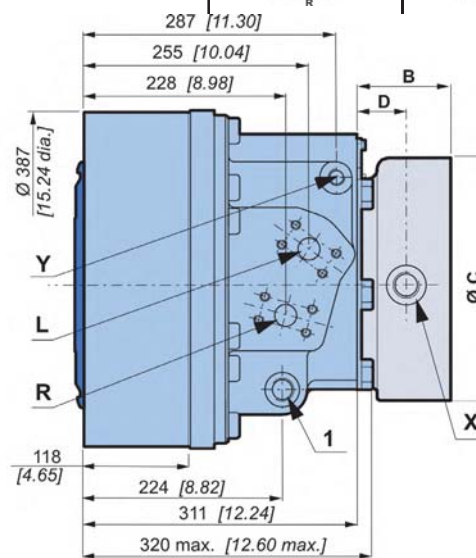
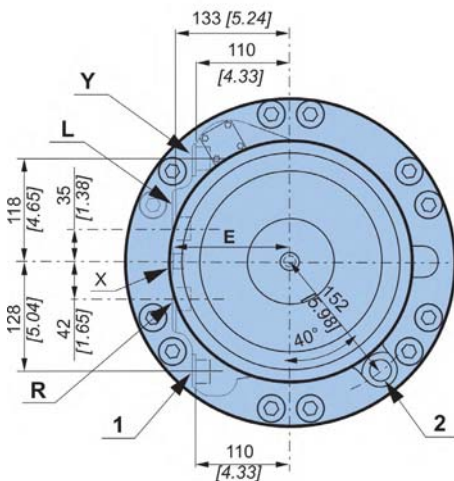

	C	P 2 1	T 4 2	T 5 0	T 8 3
B	108,5 [4,27]	148,0 [5,83]	157,5 [6,20]	159,0 [6,26]	
C	Ø280 [11,02 dia.]	Ø375 [14,76 dia.]	Ø375 [14,76 dia.]	Ø375 [14,76 dia.]	
D	57 [2,24]	63,5 [2,50]	63,5 [2,50]	63,5 [2,50]	
E	138,5 [5,45]	183,5 [7,22]	183,5 [7,22]	183,5 [7,22]	

Also see "Brake" section (thumbnail opposite).



Dimensions for Twin-Lock™ valving

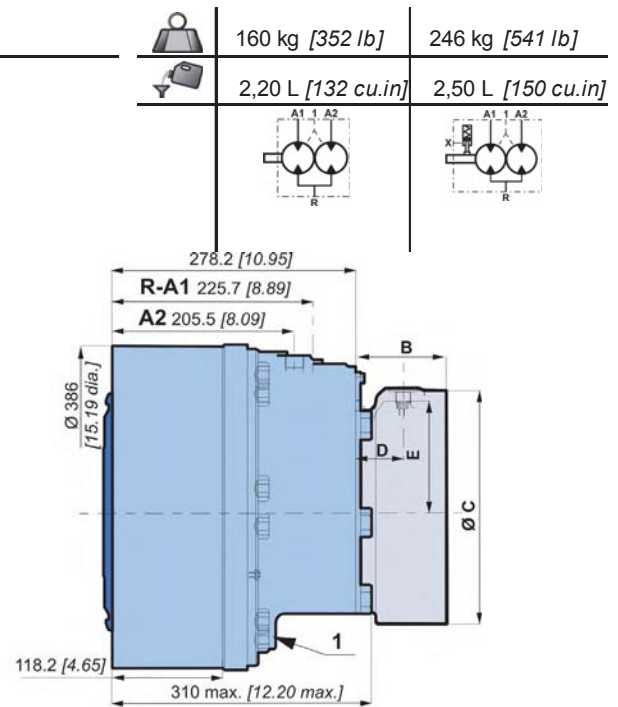
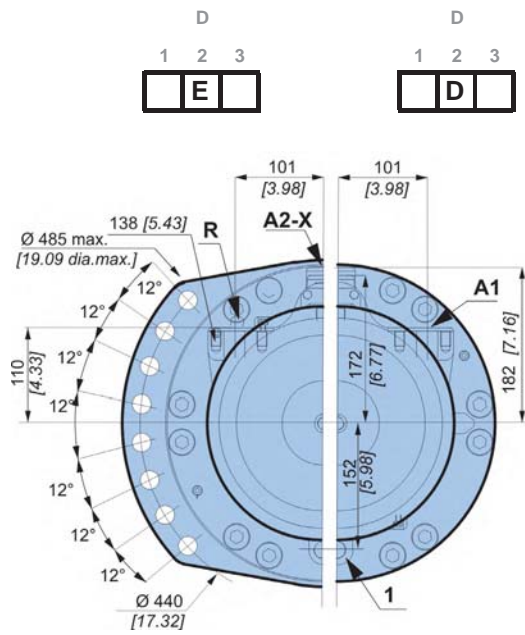

Dimensions for Twin-Lock™ / 2-displacement valving

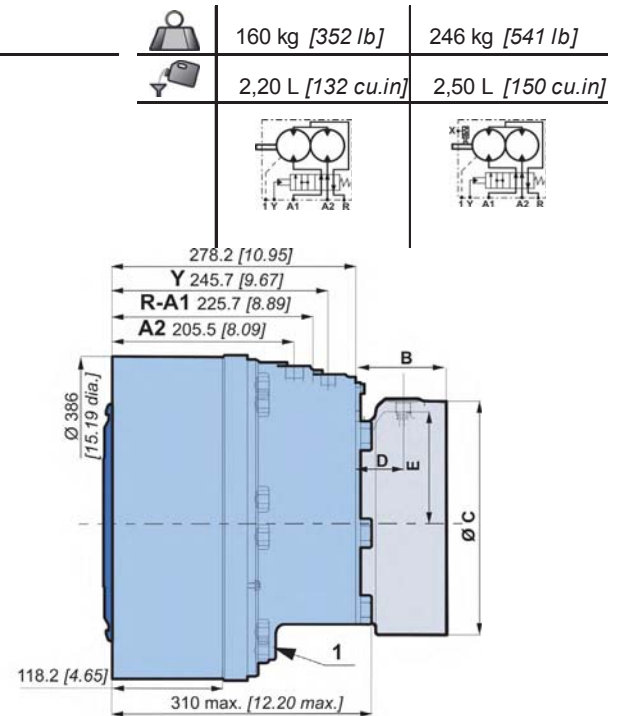
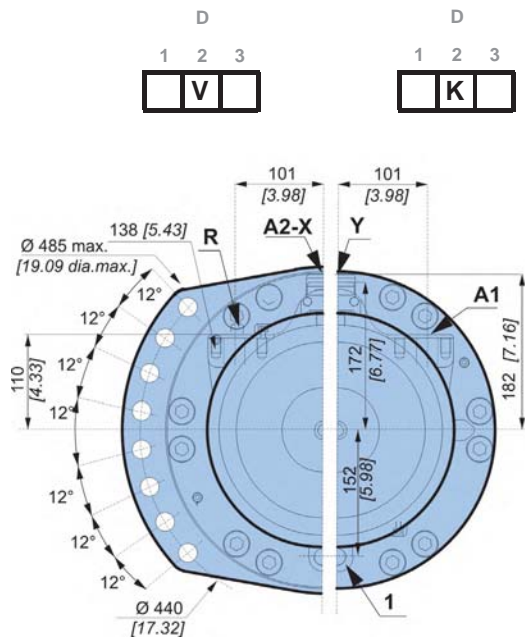

	C	P 2 1	T 4 2	T 5 0	T 8 3
B	108,5 [4,27]	148,0 [5,83]	157,5 [6,20]	159,0 [6,26]	
C	Ø280 [11,02 dia.]	Ø375 [14,76 dia.]	Ø375 [14,76 dia.]	Ø375 [14,76 dia.]	
D	57 [2,24]	63,5 [2,50]	63,5 [2,50]	63,5 [2,50]	
E	138,5 [5,45]	183,5 [7,22]	183,5 [7,22]	183,5 [7,22]	

i Also see "Brake" section (thumbnail opposite).

Modularity and Model code

Wheel motor

Shaft motor

Valving systems and hydrobases

Brake



Options

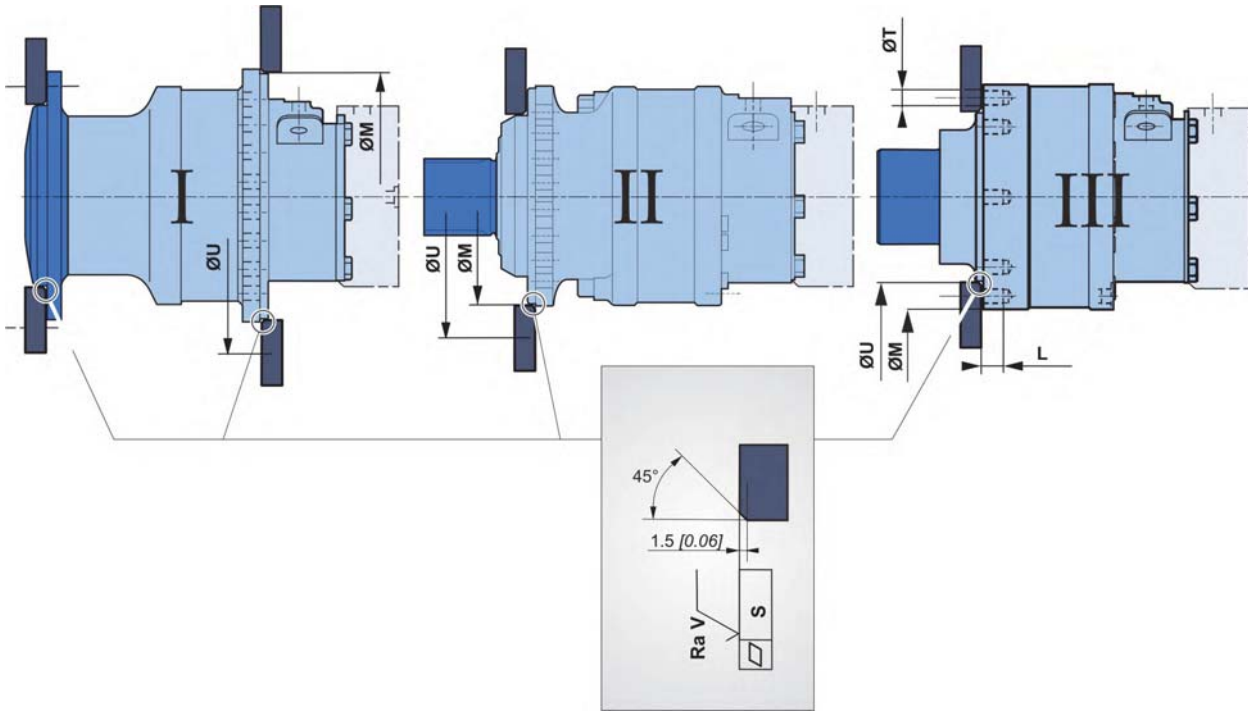

Chassis mountings



Take care over the immediate environment of the connections.

	$\varnothing M^{(1)}$ mm [in]	$\varnothing U$ mm [in]	$\varnothing T$ mm [in]	L mm [in]	S mm [in]	Ra V $\mu\text{m} [\mu\text{in}]$		Class	 * N.m [lb.ft]
I	380 [14,96]	440 [17,32]	-	-	0,2 [0,008]	12,5 [0,49]	2 x 8 M20 x 2	8,8	410 [302,4]
II		485 [19,09]	-	-			12 x M20 x 2		
III	300 [11,81]	392 [15,43]	22,5 [0,886]	30 [1,181]					

(1) +0,3 [+0,012]
+0,2 [+0,008]

* : Min. values for torque and load to be transmitted.



Hydraulic connections

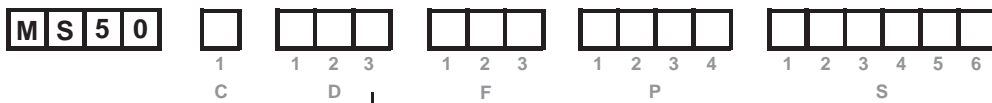
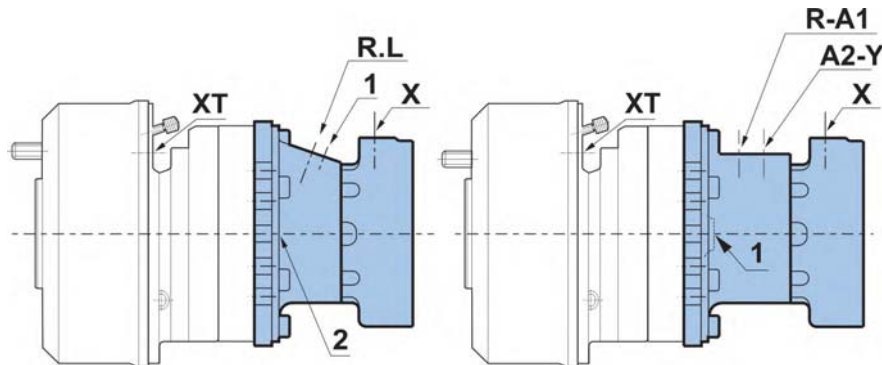

	Old standards	Standards	Power supply	Case drain	2 nd displacement control	Control of parking break	Control of drum break
			R-L	1, 2		X	XT
1	ISO 6 162 DIN 3 852	ISO 6 162 ISO 9 974-1	DN25 PN400	M22x1.5		M18x1.5	
6	DIN 3 852 NF E48 050	ISO 6 162 ISO 9 974-1	DN32 PN400	M22x1.5		M18x1.5	
7	ISO 6 162 SAE J514	ISO 6 162 ISO 11 926-1	DN25 PN400	7/8"-14 UNF		9/16"-18 UNF	
			R-A	1, 2	Y	X	
1	ISO 6 162 DIN 3 852	ISO 6 162 ISO 9 974-1	DN25 PN400	M22x1.5	M18x1.5	M18x1.5	
1*	ISO 6 162 DIN 3 852	ISO 6 162 ISO 9 974-1	DN25 PN400	M27x2	M20x1.5	M18x1.5	
7*	ISO 6 162 SAE J514	ISO 6 162 ISO 11 926-1	DN25 PN400	1"1/16-12 UNF	3/4"-16 UNF	9/16"-18 UNF	
			R-A1	A2	1, 2	Y	X
1	ISO 6 162 DIN 3 852	ISO 6 162 ISO 9 974-1	DN25 PN400	M27x2	M22x1.5	M18x1.5	M18x1.5
		ISO 9 974-1					M14x1.5
Max. pressures	MS	bar [PSI]	450 [6 527]	1 [15]	30 [435]	30 [435]	120 [1 740]

* : Only symmetrical valving

- You are strongly advised to use the fluids specified in brochure "Installation guide" N° 801478197L.
- To find the connections' tightening torques, see the brochure "Installation guide" N° 801478197L.

Modularity and Model code

Wheel motor

Shaft motor

Valving systems and hydrobases

Brake

Options



Efficiency

Overall efficiency

Average values given for guidance for code 0 displacement after 100 hours of operation with HV46 hydraulic fluid at 50°C [122°F].

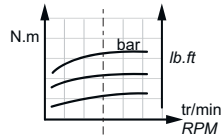
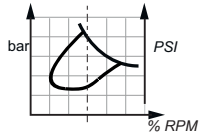

Actual output torque

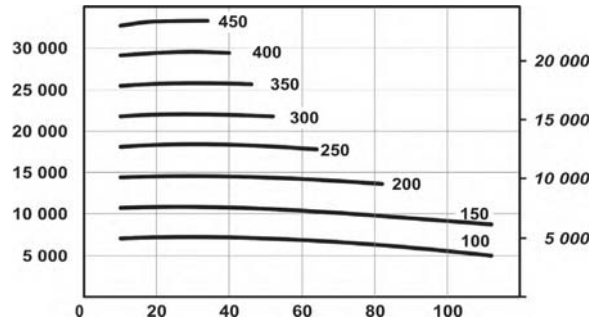
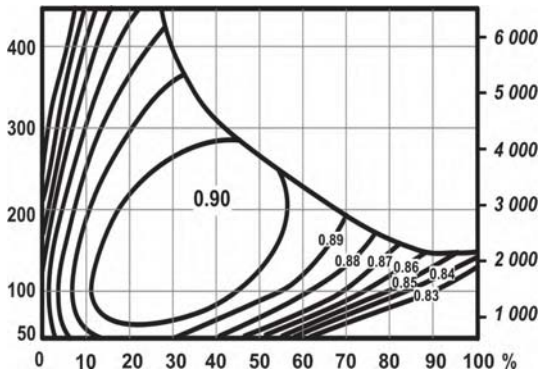

The starting torque is taken to be approximately 85% of the first value for available pressure. For a precise calculation, consult your Poclair Hydraulics application engineer.



BRAKES



Rear brake

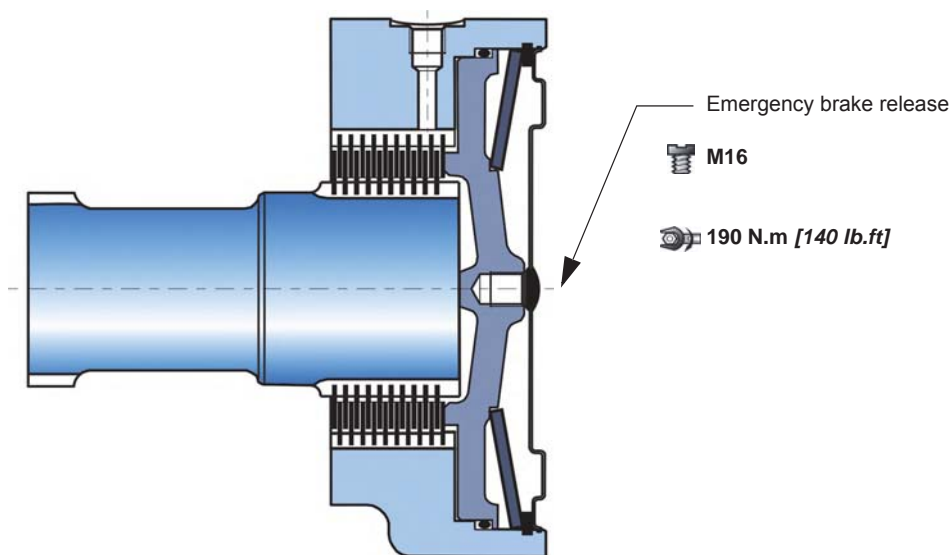

Brake principle

This is a multidisc brake which is activated by a lack of pressure. The spring exerts a force on the piston, which presses on the fixed and mobile discs, and immobilizes the shaft. The braking torque decreases in linear proportion to the brake release pressure.

C	P 2 1
Parking brake torque at 0 bars on housing (new brake)	20 900 Nm [15 420 lb.ft]
Dynamic emergency braking torque at 0 bars on housing (max. 10 uses of emergency brakes)	13 325 Nm [9 830 lb.ft]
Residual parking braking at 0 bars on housing *	15 375 Nm [11 340 lb.ft]
Min. brake release pressure	12 bar [174 PSI]
Max. brake release pressure	30 bar [435 PSI]
Oil capacity	700 cm ³ [42,7 cu.in]
Volume for brake release	70 cm ³ [4,3 cu.in]

* After emergency brake has been used



Do not run-in the multidisc brakes.



A functional check of the parking brake must be carried out each time it is used as an auxiliary brake (or emergency brake). For all vehicles capable of speeds over 25 km/hour, please contact your Poclain Hydraulics application engineer.

Modularity and Model code

Wheel motor

Shaft motor

Valving systems and hydrobases

Brake

Options



Rear brake

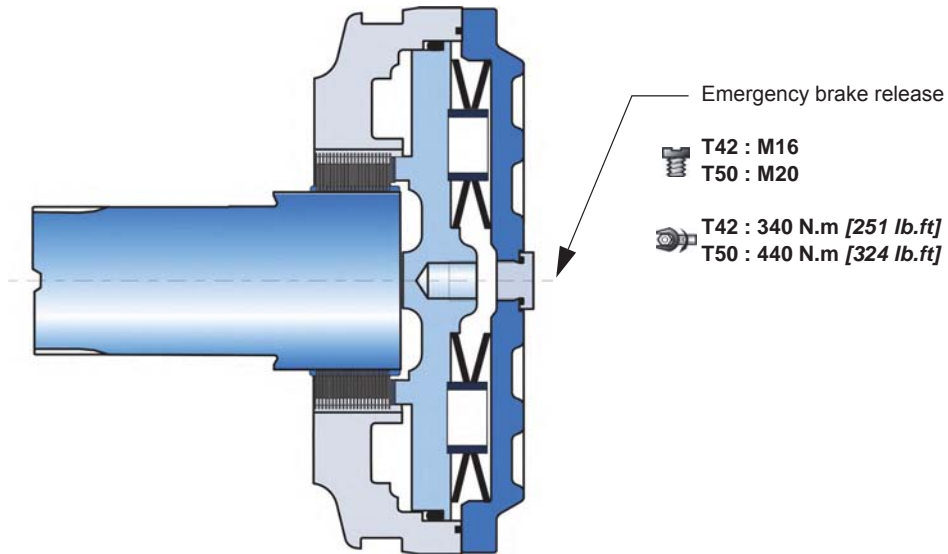
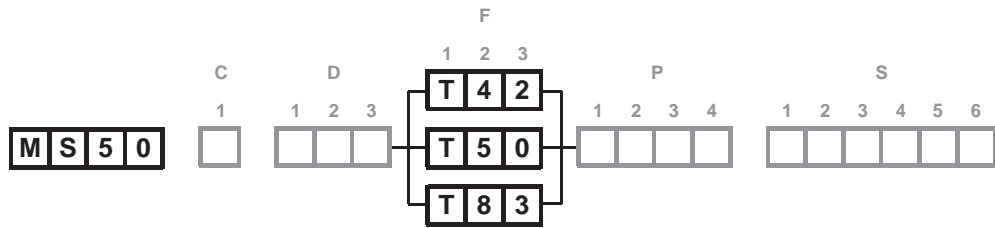

Brake principle

This is a multidisc brake which functions through the absence of pressure. The spring exerts a force on the piston, which acts on the fixed and mobile discs, and thus immobilizes the shaft. The braking torque decreases in linear proportion to the brake release pressure.

C	T 4 2	T 5 0	T 8 3
Parking brake torque at 0 bars on housing (new brake)	25 000 Nm [18 440 lb.ft]	30 000 Nm [22 130 lb.ft]	42 000 Nm [30 980 lb.ft]
Dynamic emergency braking torque at 0 bars on housing	16 250 Nm [11 990 lb.ft]	19 500 Nm [14 380 lb.ft]	27 300 Nm [20 140 lb.ft]
Residual parking braking at 0 bars on housing *	18 750 Nm [13 830 lb.ft]	22 500 Nm [16 600 lb.ft]	31 500 Nm [23 230 lb.ft]
Min. brake release pressure	12 bar [174 PSI]	12 bar [174 PSI]	14 bar [203 PSI]
Max. brake release pressure	30 bar [435 PSI]	30 bar [435 PSI]	30 bar [435 PSI]
Oil capacity	400 cm ³ [24,4 cu.in]	450 cm ³ [27,5 cu.in]	450 cm ³ [27,5 cu.in]
Volume for brake release	135 cm ³ [8,2 cu.in]	135 cm ³ [8,2 cu.in]	135 cm ³ [8,2 cu.in]

* After emergency brake has been used



Do not run-in the multidisc brakes.



A functional check of the parking brake must be carried out each time it is used as an auxiliary brake (or emergency brake). For all vehicles capable of speeds over 25 km/hour, please contact your Poclair Hydraulics application engineer.



Drum brake (432 x 102)

Diameter of brake pads : Ø 432 [17 dia.]
 Width of friction surface : 102 [4,01]

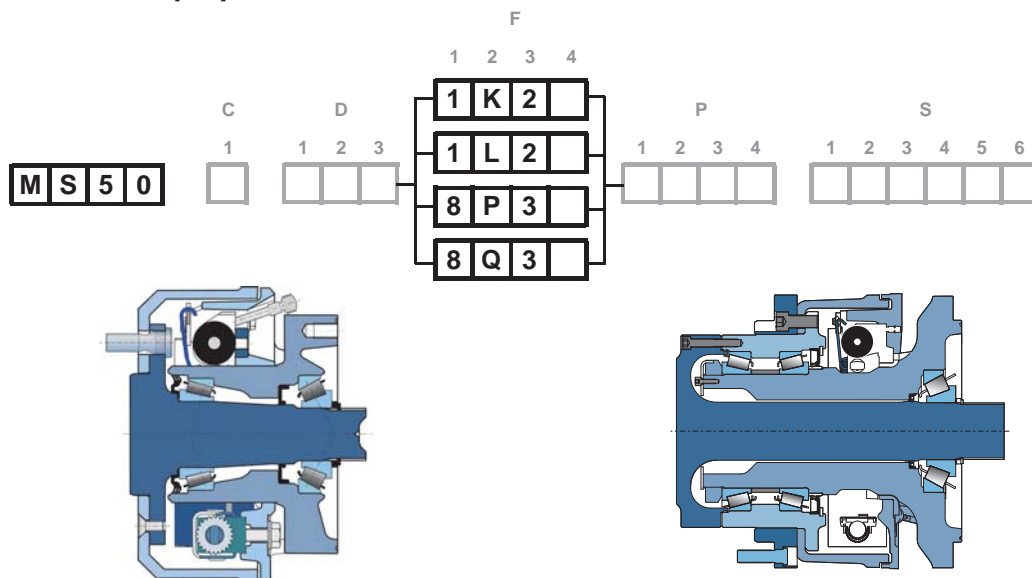

Brake pads

Asbestos free material	BERAL 1109 or JURID 505
Compensation for wear	Automatic

Hydraulically controlled dynamic braking

Max. permissible continuous brake torque	16 200 N.m [11 948 lb.ft]
Pressure to obtain max. permissible continuous brake torque	71 bar [1 028 PSI]
Max. permissible brake torque	27 000 N.m [19 914 lb.ft]
Pressure to obtain max. permissible brake torque	120 bar [1 740 PSI]

Fluid

Mineral	Yes	K
DOT 3 / DOT 4 / SAE J1703	Yes	L
Max. volume required to bring pads into contact	10.2 cm ³ [0.62 cu.in]	

Mechanically controlled parking brake

Max. braking torque	27 000 N.m [19 914 lb.ft]
Max permissible force on the cable	5 700 N [1 281 lbf]
Force required to bring pads into contact	37 N [8 lbf]
Stroke required to bring pads into contact (new brake)	A 31 mm [1.22 "] (+/- 10%)
	B 34 mm [1.34 "] (+/- 10%)

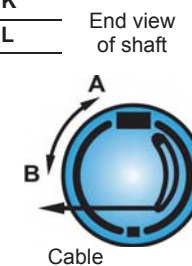

The max. braking torque can only be obtained when the brake has been run in. Consult your Poclain Hydraulics application engineer.

Control

The drum brakes can be controlled hydraulically (service brake) and by a cable (mechanical control for parking brake).



Do not use hydraulic and mechanical brake controls simultaneously.



See also 'Wheel motor' section (thumbnail opposite).



When making an encoding request, you must indicate the following information:

- The material of the brake linings,
- The type of connection at the end of the parking brake control cable,
- Fill out the technical questionnaire for validation of the brake.





OPTIONS

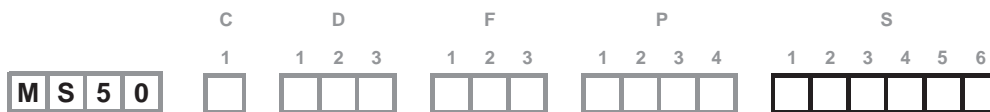

You can accumulate more than one optional part. Consult your Poclain Hydraulics sales engineer.

1 - Fluorinated elastomer seals

Nitrile seals marked in the figure below replaced by fluorinated elastomer seals.

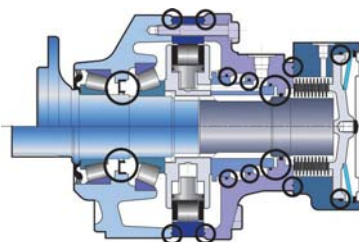

Consult your Poclain Hydraulics sales engineer.

2 - 8 - Q - Installed speed sensor or predisposition

Designation	C	L mm [in]
Connection by connector part	2	100 [3.93]
Wire connection	Q	609 [23.97]
Predisposition for speed sensor	8	-

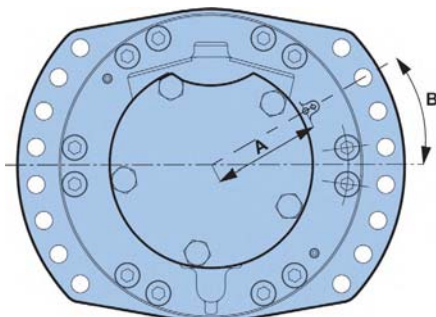

	mm [in]	mm [in]
A	118,9 [4,68]	118,9 [4,68]
B	0°	20°

2-displacement 1-displacement

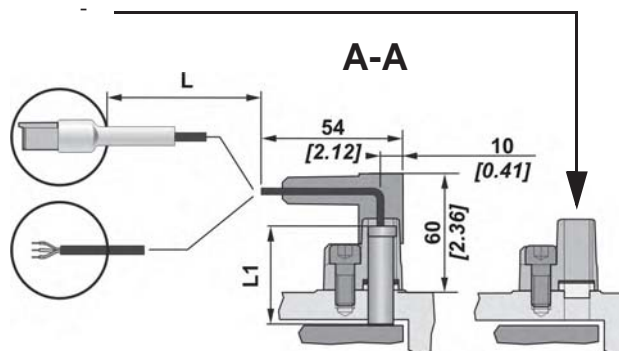

To install the sensor, see the "Motors Generic installation" brochure No. 801478197L.

Connection of sensor

Function	Color	Number on connector
Power supply	Brown	1
Signal	Black	2
Earth	Blue	3



Technical characteristics of the speed sensor

Supply voltage	10 - 30 V
Type of output	NPN
Residual fluctuation	< 10%
Max. load current (black wire)	20 mA
Voltage drop	< 1.5V
Operating temperature	-10°C to +110°C [14°F to 230°F]
Reference of male connector	DEUTSCH DTM04-3P
Number of pulses per revolution	56
L1	50
3-conductor cable	Ø 6 - 3 x 0.5 mm ² sheath PVC insulator

Modularity and Model code

Wheel motor

Shaft motor

Valving systems and hydrobases

Brake

Options



6 - Industrial support

Reduction of around 50% from the rated value in the bearings' preload value.



For a precise calculation, consult your Poclain Hydraulics application engineer.

7 - Diamond™

Special treatment of the motor core which considerably increases its strength, making the motor much more tolerant to temporary instances of the operating conditions being exceeded.

A - Hollow shaft

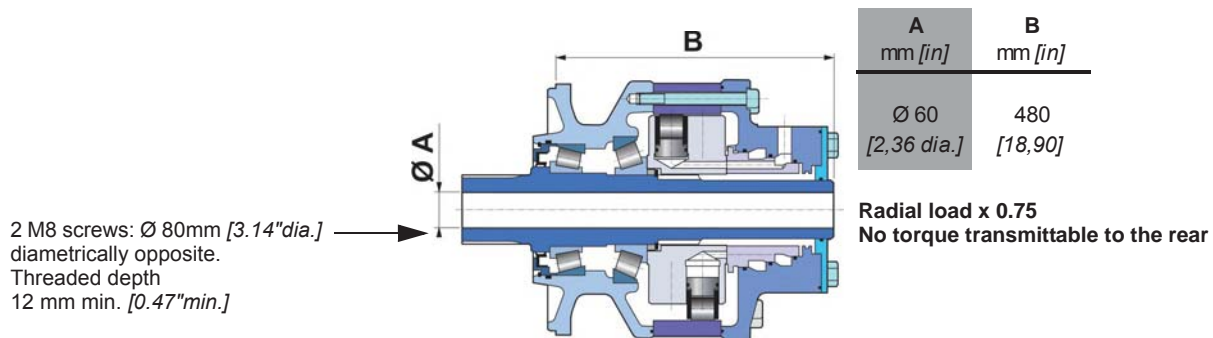

B - Drain on the bearing support

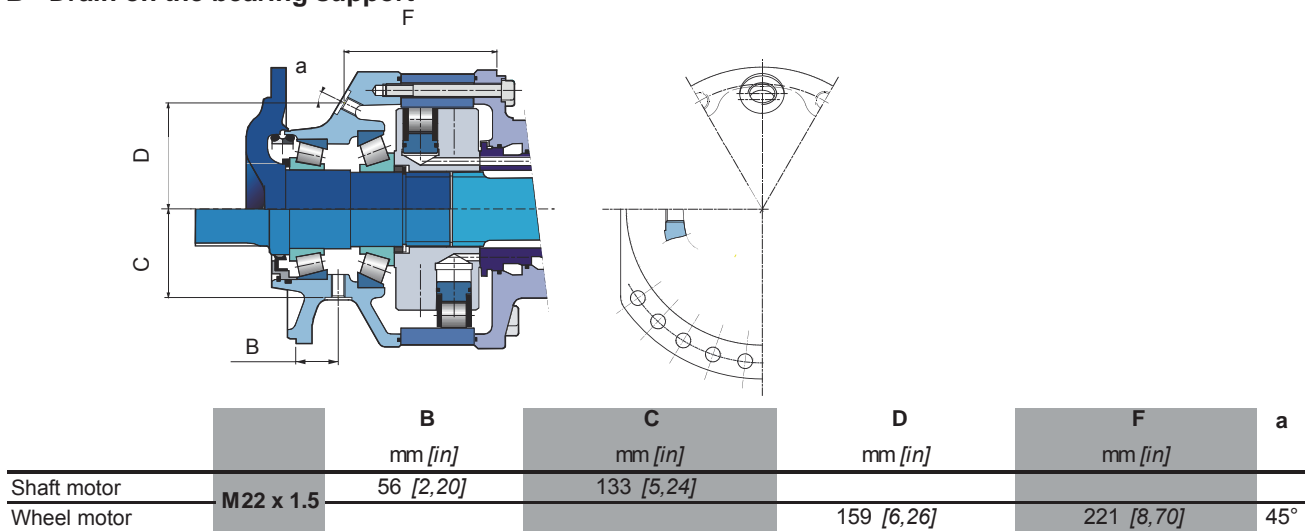



E - Reinforced sealing

Requires reinforced seals and, for an unbraked motor, a rear reinforced plate (R50 - 15 [0.59] thick, instead of 6 [0.237]).

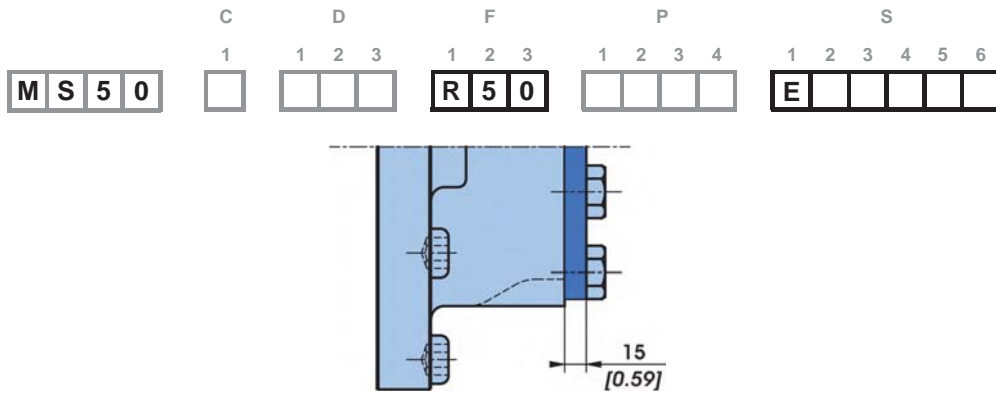

G - Special wheel rim mounting

Enables certain combinations different from the standard mountings.



Consult your Poclair Hydraulics sales engineer.

J - Treated shaft

Heat treatment on the indicated bearing radius and splines.

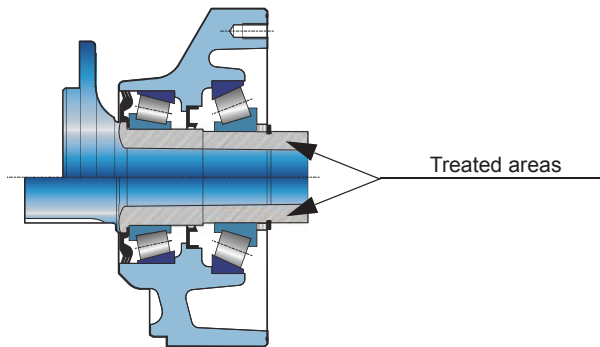

N - Drain on the bearing

A purge screw enables the motor to be mounted vertically, the shaft oriented upward.

Modularity and Model code

Wheel motor

Shaft motor

Valving systems and hydrobases

Brake

Options



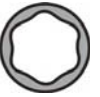

Modularity and
Model code

Wheel motor

Shaft motor

Valving systems
and hydrobases

Brake

Options



Poclain Hydraulics reserves the right to make any modifications it deems necessary to the products described in this document without prior notification. The information contained in this document must be confirmed by Poclain Hydraulics before any order is submitted.

Illustrations are not binding.

The Poclain Hydraulics brand is the property of Poclain Hydraulics S.A.

-  29/07/2016
-  801 478 124G
-  801 478 194H
-  801 578 107J
-  801 578 119W
-  801 578 131K
-  A50153P
-  Not available
-  A14246K

