

MS125

HYDRAULIC MOTORS



T E C H N I C A L C A T A L O G



CHARACTERISTICS

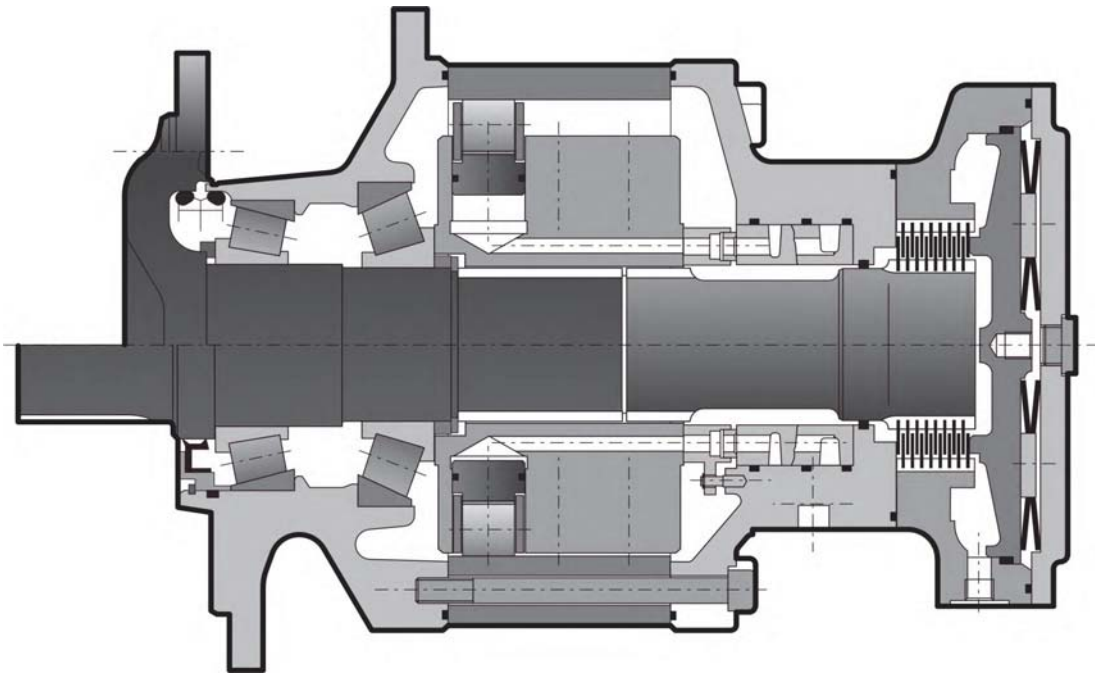

Motor inertia 2 kg.m²

	C	Displacement		Theoretical torque		Max.power *		Max. speed		Max. pressure P		
		①	②	①	②	①	②	①	②	1	2	
		cm ³ /tr [cu.in/rev.]	cm ³ /tr [cu.in/rev.]	at 100 bar Nm	at 1000 PSI [lb.ft]	kW [HP]	kW [HP]	tr/min[RPM] speed 1C	tr/min[RPM] speed 2C	bar [PSI]	bar [PSI]	
Cams with equal lobes	8	10 000 [609,9]	5 000 [305,0]	15 900 [8 086]				130	90	105	450 [6 527]	420 [6 092]
	0	12 500 [762,4]	6 250 [381,2]	19 875 [10 107]	240 [322]	160 [215]	105	70	85	380 [5 511]	335 [4 859]	
	2	15 000 [914,9]	7 500 [457,4]	23 850 [12 128]			85	60	70	320 [4 641]	280 [4 061]	
Cams with unequal lobes	A	12 500 [762,4]	7 500 [457,4]	19 875 [10 107]	240 [322]	160 [215]	100	65	80	380 [5 511]	335 [4 859]	
			5 000 [305,0]									

- ① First displacement
- ② Second displacement



* For higher power value, please consult your Poclain Hydraulics application engineer.

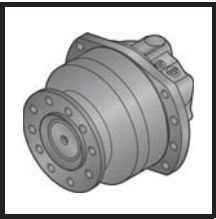
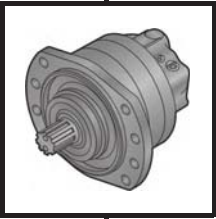
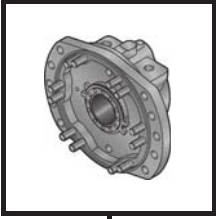
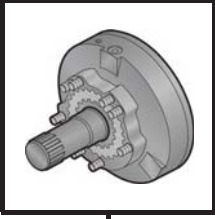
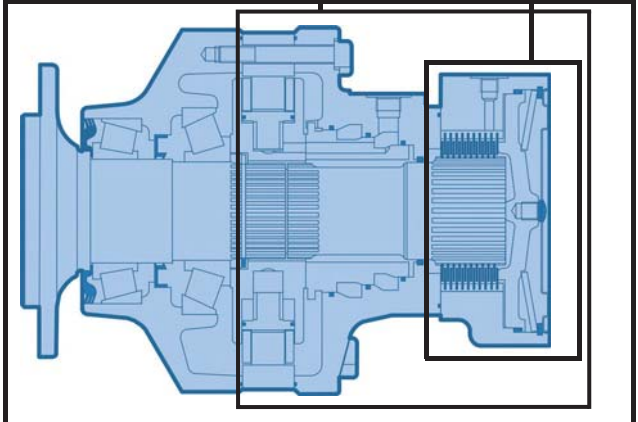

CONTENT

	MODULARITY	4	Modularity and Model code
	MODEL CODE	6	
	WHEEL MOTOR	9	Wheel motor
	Dimensions for standard (4311) 1-displacement motor	9	
	Dimensions for standard (4311) 2-displacement motor	9	
	Studs	10	
	Load curves	11	
	SHAFT MOTOR	13	Shaft motor
	Dimensions for standard (3A51) 1-displacement motor	13	
	Dimensions for standard (3A51) 2-displacement motor	13	
	Coupling for male splines	14	
	Coupling for shrink discs	15	
	Load curves	15	
	Coupling for female splines	16	
	VALVING SYSTEMS AND HYDROBASES	17	Valving systems and hydrobases
	Dimensions for 1-displacement valving	17	
	Dimensions for 2-displacement symetrical valving	18	
	Chassis mountings	19	
	Hydraulic connections	20	
	Efficiency	21	
	Pressure drop and charge pressure	22	
	BRAKES	23	Brake
	Rear brake	23	
	OPTIONS	25	Options



MODUL

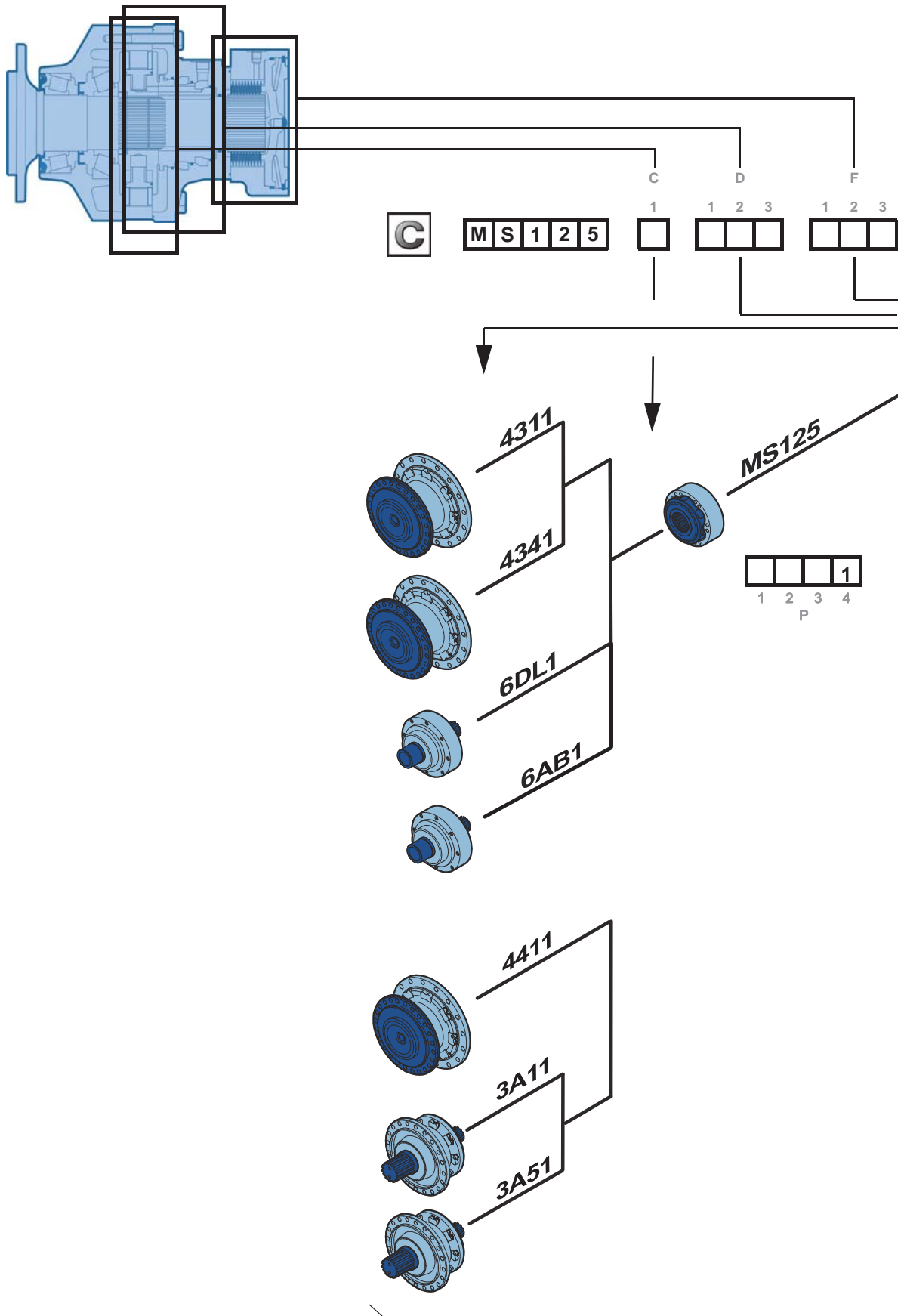

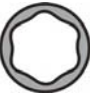

ARITY

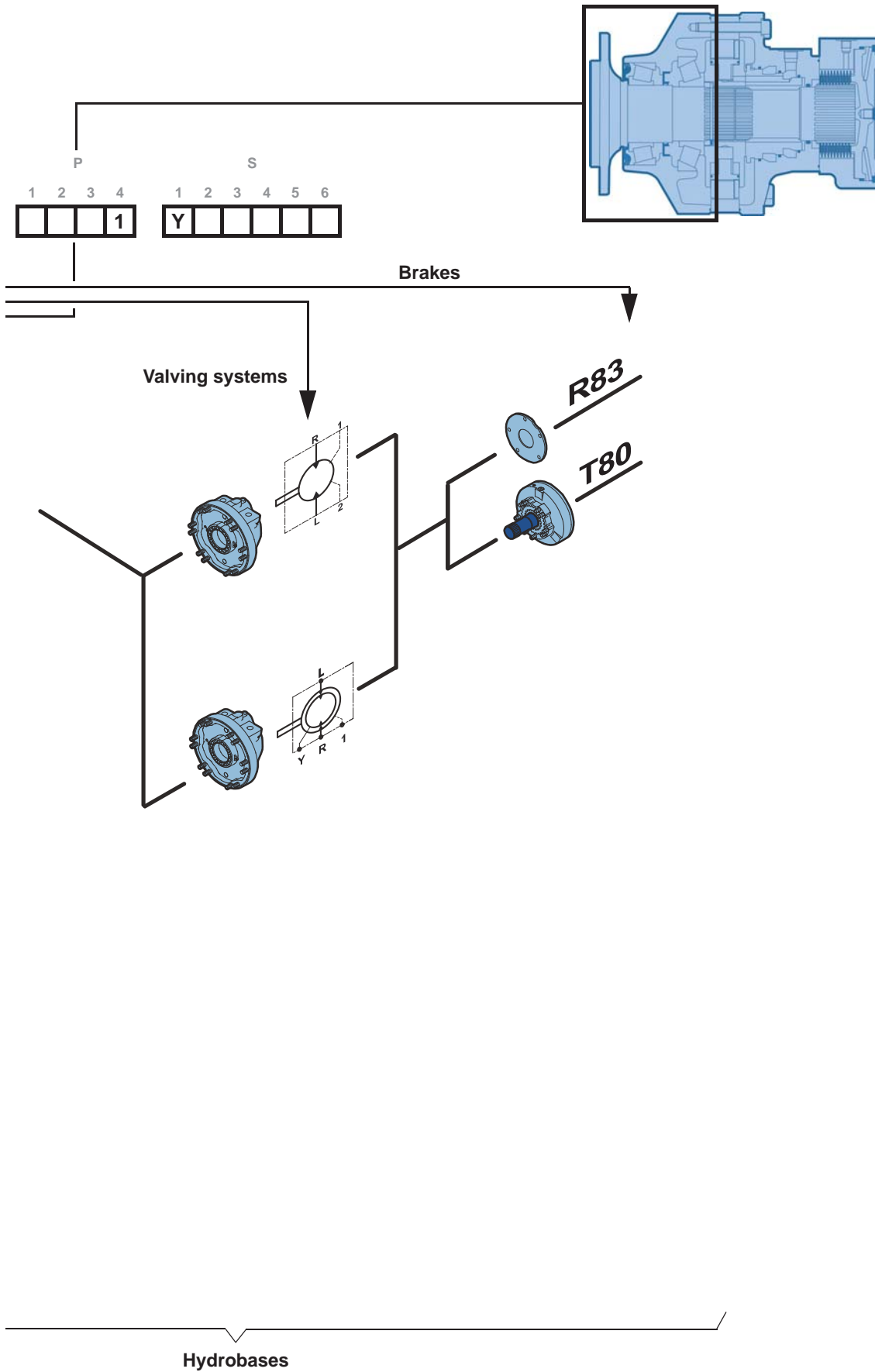

Modularity and Model code

Wheel motor

Shaft motor

Valving systems and hydrobases

Brake

Options



MODEL

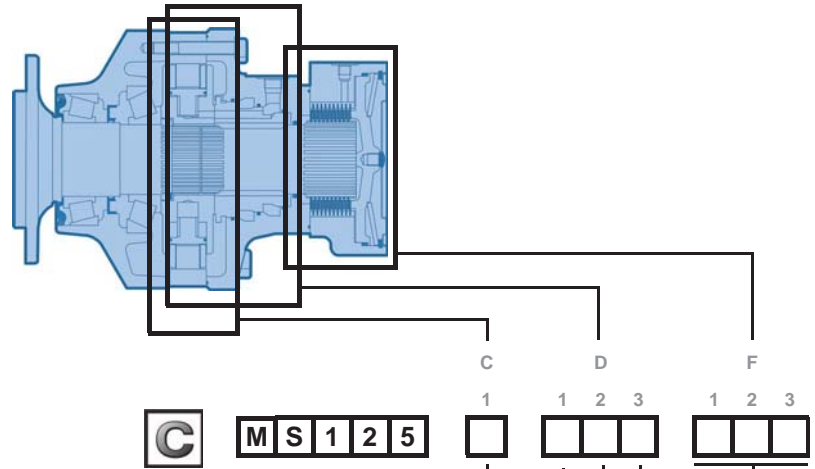

C1
Cam ring type

		1 displacement	2 displacements	
		cm ³ /tr [cu.in/rev.]		
Cams with equal lobes	10 000 [609.9]	5 000 [305.0]	8	
	12 500 [762.4]	6 250 [381.2]	0	
	15 000 [914.9]	7 500 [457.4]	2	
Cams with unequal lobes	12 500 [762.4]	7 500 [457.4]	A	
		5 000 [305.0]		

D2
Valving cover

High Flow (HF) distribution	Without mounting	B
	Lug fixing	C

D3
Connection type

Without cover	0
HP: ISO 6162 (SAE flanges) DN 32	J
BP: ISO 9974-1 (Metric ports)	
HP: ISO 6162 (SAE flanges) DN 32	K
BP: ISO 1179-1 (GAZ ports)	

D1
Valving type

1-displacement valving	1	
2-displacement symmetrical valving	Ratio 2	A
	Ratio <2	B
	Ratio >2	C

F1-F3
Rear brake

Brakes (Screwed environmental cover)	T 8 0
Without brake (Reinforced plate)	R 8 3



CODE

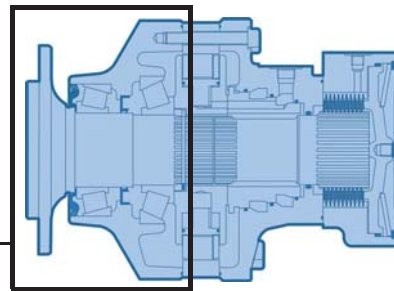

Modularity and Model code

Wheel motor

Shaft motor

Valving systems and hydrobases

Brake

Options

P		S							
1	2	3	4	1	2	3	4	5	6
				1	Y				
				P1					
				Front unit					
				0 Without bearing support					
				3 Flange on shaft side					
				4 Flange on cam side					
				6 Torque motor					
				P2					
				Bearing support					
				0 Without shaft					
				3 Long bearing support; Ø425 24 studs M24 x 2 x 115 mm					
				4 Short bearing support; Ø425 24 studs M24 x 2 x 95 mm					
				A Bearing support for male shaft					
				P3					
				Shaft type					
				0 Without shaft					
				Flange					
				1 Without studs					
				2 With studs + nuts					
				3 With studs					
				Spline (if P2 = A)					
				1 NF E 22141 splines					
				5 DIN 5480 splines					
				B Female splines DIN 5480					
				Shrink disks (if P2 = A)					
				L Shaft for shrink disks					

S1	
	Standard
	Predisposal for speed sensor
	Additional drain on valving system
Y	High speed/Low pressure drop (Butterfly valving)
	Grip washer (when using T80)

S2-S6	
Options	
	Without Options
	0
	T4 Speed sensor installed
	2
	TR Speed sensor installed
	S
	TD Speed sensor installed
	Q
	Industrial bearing support
	6
	Diamond™
	7
	Hollow shaft
	A
	Drain on the bearing support
	B
	Special paint or no paint
	D
	Reinforced sealing
	E
	Special wheel rim mounting
	G
	Surface heat treatment of the shaft
	J



Methodology :

This document is intended for manufacturers of machines that incorporate Poclain Hydraulics products. It describes the technical characteristics of Poclain Hydraulics products and specifies installation conditions that will ensure optimum operation. This document includes important comments concerning safety. They are indicated in the following way:



Safety comment.

This document also includes essential operating instructions for the product and general information. These are indicated in the following way:



Essential instructions.



General information .



Information on the model number.Information on the model code.



Weight of component without oil.



Volume of oil.



Units.



Tightening torque.



Screws.



Information intended for Poclain-Hydraulics personnel.

The views in this document are created using metric standards.
The dimensional data is given in mm and in inches (inches are between brackets and italic)





WHEEL MOTOR

Dimensions for standard (4311) 1-displacement motor

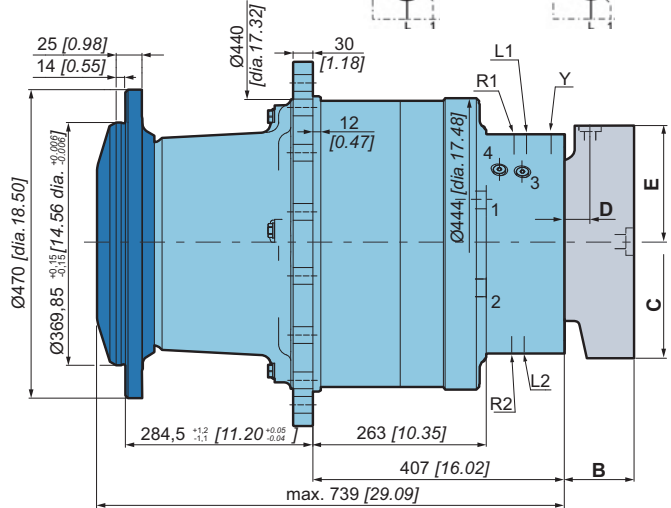
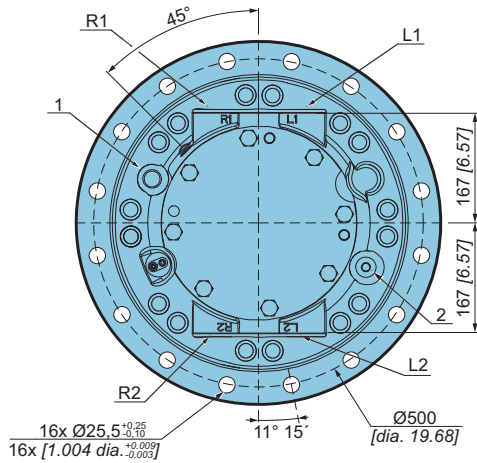

	460 kg [1 012 lb]	563 kg [1 239 lb]
	11,00 L [660 cu.in]	9,00 L [540 cu.in]

Modularity and Model code

Wheel motor

Shaft motor

Dimensions for standard (4311) 2-displacement motor

For a small displacement, there is no preferred orientation for this motor.

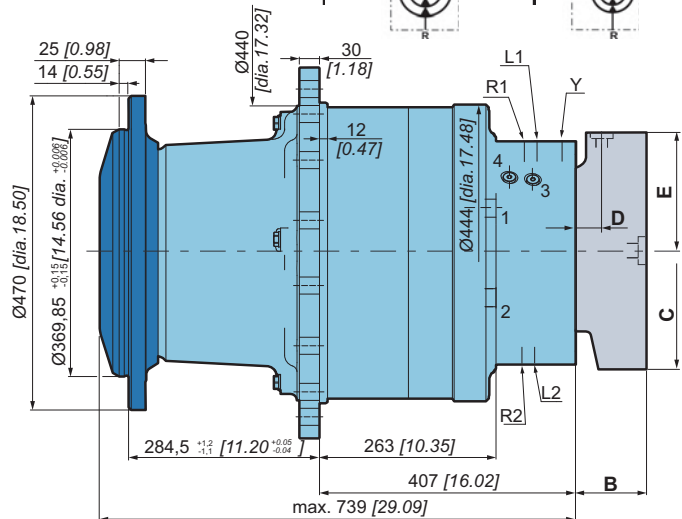
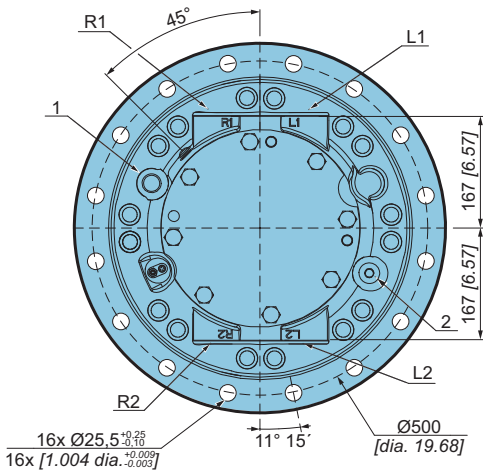

	460 kg [1 012 lb]	563 kg [1 239 lb]
	11,00 L [660 cu.in]	9,00 L [540 cu.in]

Valving systems and hydrobases

Brake

Options



Also see 'Valving systems and hydrobases' section (thumbnail opposite).

	T 8 0
B	189,0 [7,44]
C	Ø376 [14,80 dia.]
D	44,0 [1,73]
E	181,0 [7,13]



Also see "Brake" section (thumbnail opposite).



For speed ≥ 90 rpm, the bearing support must be flushed: motor must be ordered with drain on the bearing support (option B).





Support types

	C				D			F			P				S						
	1	1	2	3	1	2	3	1	2	3	1	2	3	4	1	2	3	4	5	6	
	M	S	1	2	5									1	Y						

C	A mm [in]	B mm [in]	C mm [in]	D mm [in]	E mm [in]	N mm [in]	Wheel rim mountings	L mm [in]
4 3 1 1 1 2 3 4 P	Ø 370 [14,57 dia.]	Ø 425 [16,73 dia.]	Ø 470 [18,50 dia.]	284 [11,18]	Ø 445 [17,52 dia.]	Ø 26 [1,02 dia.]	24 x M24x2	26 [1,02]
4 4 1 1 1 2 3 4 P	Ø 370 [14,57 dia.]	Ø 425 [16,73 dia.]	Ø 470 [18,50 dia.]	239 [9,41]	Ø 445 [17,52 dia.]	Ø 26 [1,02 dia.]	24 x M24x2	25 [0,98]

Studs

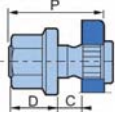
		P mm [in]	C min. mm [in]	C max. mm [in]	D mm [in]	Class	 (1) * N.m [lb.ft]	 (2) * N.m [lb.ft]
Studs	M24 x 2	95 [3,74] 115 [4,53]	5 [0,20]	39 [1,54] 59 [2,32]	30 [1,18]	 12,9	910 [671,2]	1 150 [848,2]
Screws	M24 x 2	-	-	-	-	12,9	910 [671,2]	1 150 [848,2]

(*) The tightening torques are given for the indicated loads.

(1) **Wheel rim** : Suggested tightening torque for wheel rim mountings (Re steel disc > 240 N/mm² [>34 800 PSI]).

(2) **Standard** : Suggested tightening torque in other cases (Re steel flange > 360 N/mm² [>52 215 PSI])



See generic installation motors N°801478197L.



Load curves

Permissible radial loads

Max. permissible loads: 0 tr/min [0 RPM]; 0 bar [0 PSI]

Continuous permissible loads:
 > 0 tr/min [> 0 RPM]; 275 bar [3 988 PSI].

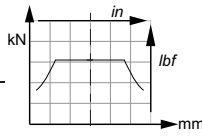

Service life of bearings

Test conditions :

L : Millions B10 revolutions at 150 bars (average pressure), with 25 cSt fluid, code 0 displacement, without axial load.

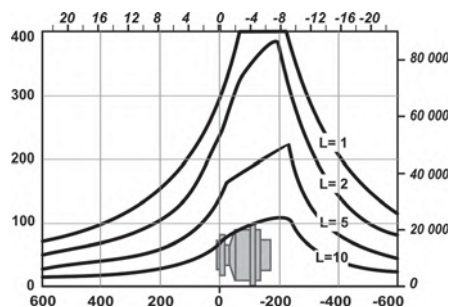
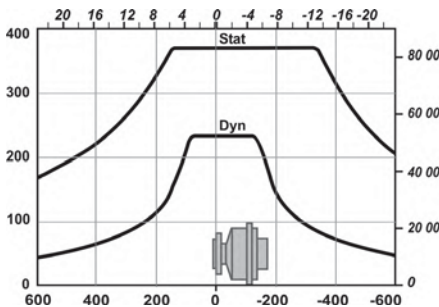
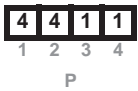
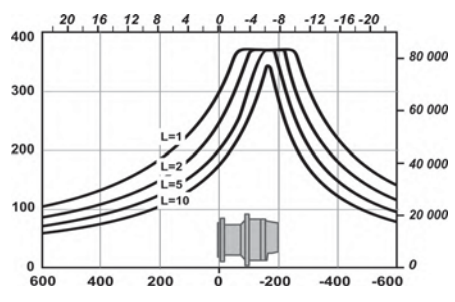
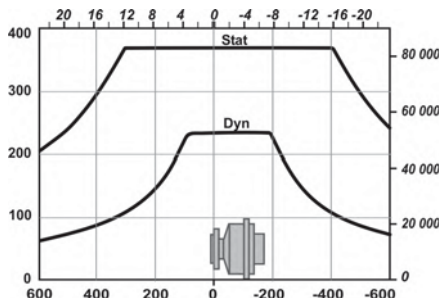

The service life of the components is influenced by the pressure. You must check that the combination of forces applied (Axial load / Radial load) is compatible with the permissible loads for the components, and that the resulting service lives of these components complies with the application's specifications. For an accurate calculation, consult your Poclair Hydraulics application engineer. ア

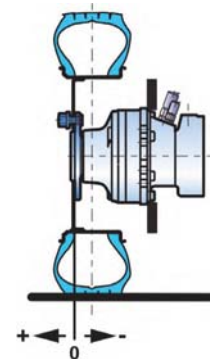

Modularity and Model code

Wheel motor

Shaft motor

Valving systems and hydrobases

Brake

Options



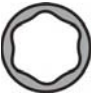

SHAFT MOTOR

Dimensions for standard (3A51) 1-displacement motor

	470 kg [1 034 lb]	573 kg [1 261 lb]
	11,00 L [660 cu.in]	9,00 L [540 cu.in]

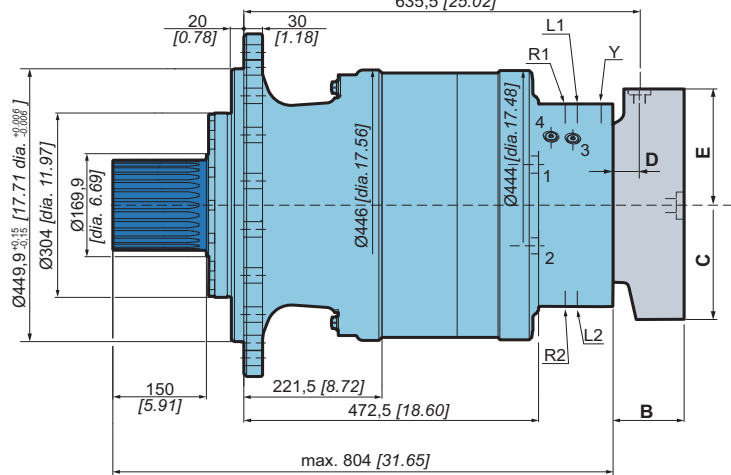
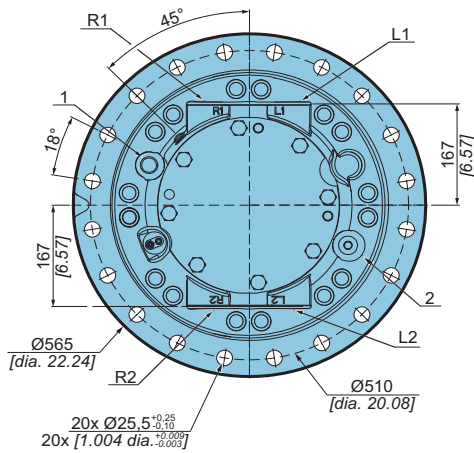

Dimensions for standard (3A51) 2-displacement motor

	470 kg [1 034 lb]	573 kg [1 261 lb]
	11,00 L [660 cu.in]	9,00 L [540 cu.in]

For a small displacement, there is no preferred orientation for this motor.

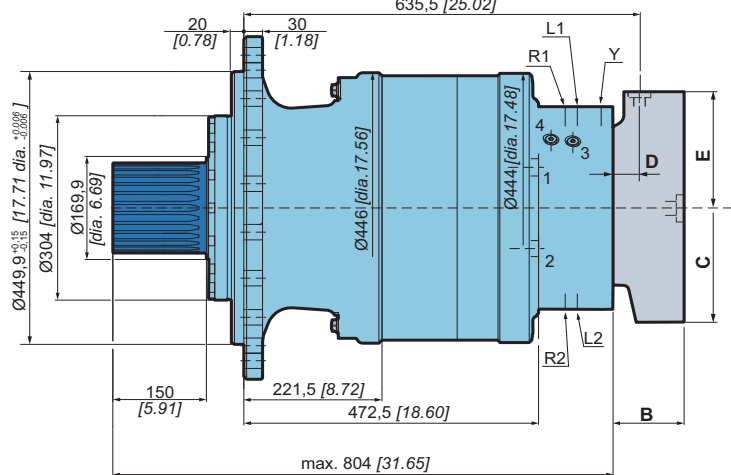
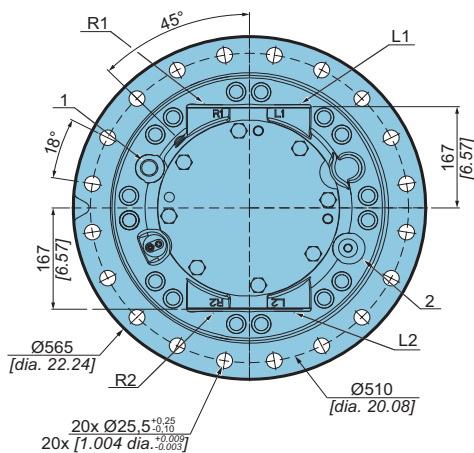

Also see 'Valving systems and hydrobases' section (thumbnail opposite).

	T 8 0
B	189,0 [7,44]
C	Ø376 [14,80 dia.]
D	44,0 [1,73]
E	181,0 [7,13]



Also see "Brake" section (thumbnail opposite).



For speed ≥ 90 rpm, the bearing support must be flushed: motor must be ordered with drain on the bearing support (option B).

Modularity and Model code

Wheel motor

Shaft motor

Valving systems and hydrobases

Brake

Options



Support types



C	A		B		C		D		E		F		G		Diagram
	mm [in]	mm [in]	mm [in]	mm [in]	mm [in]	mm [in]	mm [in]	mm [in]	mm [in]	mm [in]	mm [in]	mm [in]	mm [in]		
3 A 1 1 <small>1 2 3 4</small> P	NF E22-141 splines														
	Nominal Ø 150 [5,91]														
	Module 3.75														
Z 38															
3 A 5 1 <small>1 2 3 4</small> P	DIN 5480 splines														
	Nominal Ø 150 [5,91]														
	Module 5														
Z 28															
6 D L 1 <small>1 2 3 4</small> P	Ø 160 [6,30 dia.]														
	Ø 200 [7,87 dia.]														
	230 [9,06]														
495 [19,49]															
Ø 352 [13,86 dia.]															
Ø 394 [15,51 dia.]															
16 x M24															
6 A B 1 <small>1 2 3 4</small> P	DIN 5480 splines														
	Nominal Ø 150 [5,91]														
	Module 5														
Z 28															

Coupling for male splines

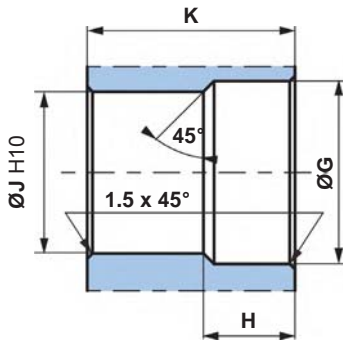

Standard DIN 5480

Pressure angle 30°. Centering on flanks. Slide fit (7H quality).

N : Nominal Ø.
 Mo : Module.
 Z : Number of teeth.

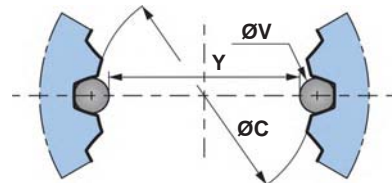

C	Ø G	H	Ø J	K	N	Mo	Z	Offset	Ø C (H10)	Ø V	Y	Tolerance
	mm [in]	mm [in]	mm [in]	mm [in]	mm [in]			mm [in]	mm [in]	mm [in]	mm [in]	µm [µin]
3 A 5 1 <small>1 2 3 4</small> P	152 [5,98]	33 [1,30]	140 [5,51]	149 [5,87]	150 [5,91]	5	28	2,25 [0,0886]	140 [5,51]	9 [0,35]	131,104 [5,16]	+ 87 / 0 [+3.425 / 0]

General tolerances : ± 0.25 [±0.0098].

Material: Ex: 42CrMo4.

Hardening treatment to obtain R = 800 to 900 N/mm² [R = 116 030 to 130 533 PSI].



Coupling for shrink discs

	A	B	C	D
	mm [in]	mm [in]	mm [in]	mm [in]
6 D L 1	Ø 160 [6,30 dia.]	140 [5,51]	10 [0,394]	0,5 [0,0197]
1 2 3 4 P				

R min. : 640 N/mm² [132 800 PSI]

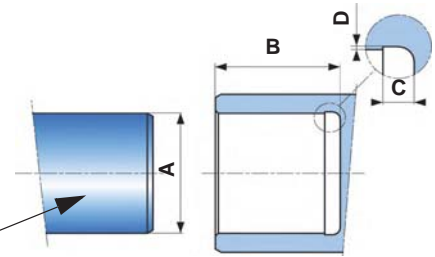

Load curves

Permissible radial loads

Max. permissible loads: 0 tr/min [0 RPM]; 0 bar [0 PSI]

Continuous permissible loads:
> 0 tr/min [> 0 RPM]; 275 bar [3 988 PSI].

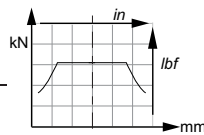

Service life of bearings

Test conditions :

L : Millions B10 revolutions at 150 bars (average pressure), with 25 cSt fluid, code 0 displacement, without axial load.

3	A	1	1
3	A	5	1
1	2	3	4
P			

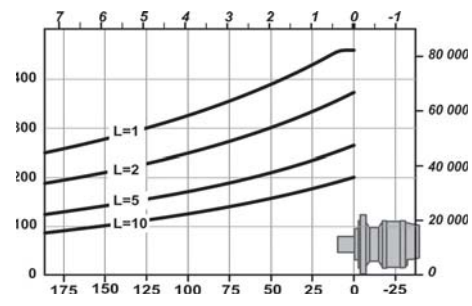
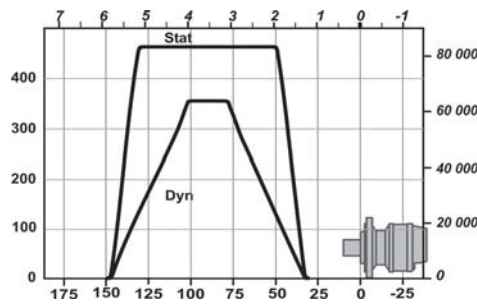

6	D	L	1
6	A	B	1
1	2	3	4
P			

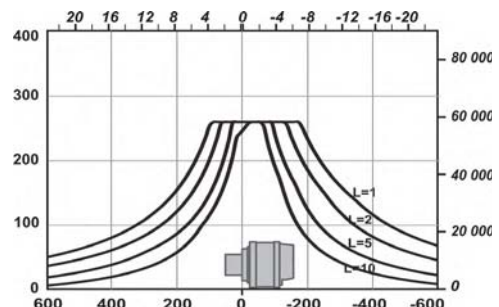
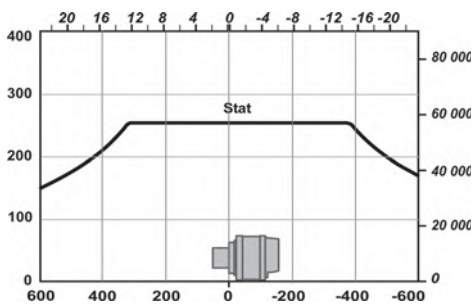

The service life of the components is influenced by the pressure. You must check that the combination of forces applied (Axial load / Radial load) is compatible with the permissible loads for the components, and that the resulting service lives of these components complies with the application's specifications. For an accurate calculation, consult your Poclain Hydraulics application engineer. ア

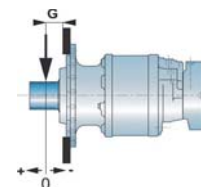

	G	mm [in]
3 A 1 1	151	[5,94]
3 A 5 1	151	[5,94]
6 D L 1	65,75	[2,589]
6 A B 1	65,75	[2,589]



Coupling for female splines



Splined DIN 5480
 Pressure angle: 30°
 Nominal diameter: 150
 Teeth quantity: 28
 Modulus: 5
 Tolerance class: 8

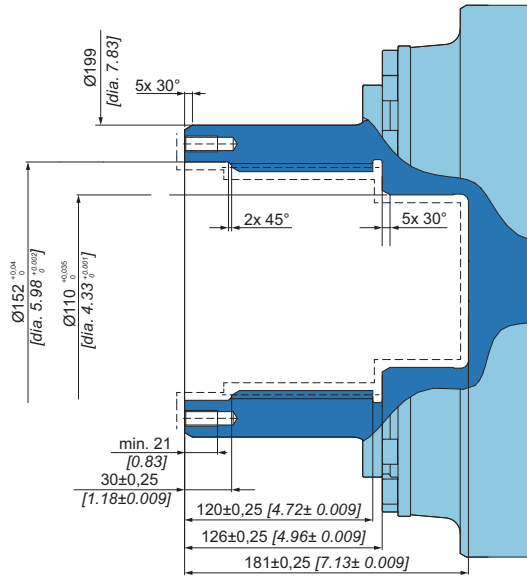

Recommended customer shaft design to be used with bearing support 6AB1

	Torque arm motor	Flange mounted motor
A ⁽¹⁾	Ø110 [4,33 dia.]	Ø110 [4,33 dia.]
B ⁽²⁾	Ø152 [5,98 dia.]	Ø152 [5,98 dia.]
E	10,0 [0,39]	5,0 [0,20]
F	98,0 [3,86]	98,0 [3,86]
G	58,0 [2,28]	55,0 [2,17]
LU	99,0 [3,90]	99,0 [3,90]

(1) - 0.01 [-0.0004] (2) - 0.11 [+0.004]
 - 0.03 [-0.001] - 0.13 [-0.005]

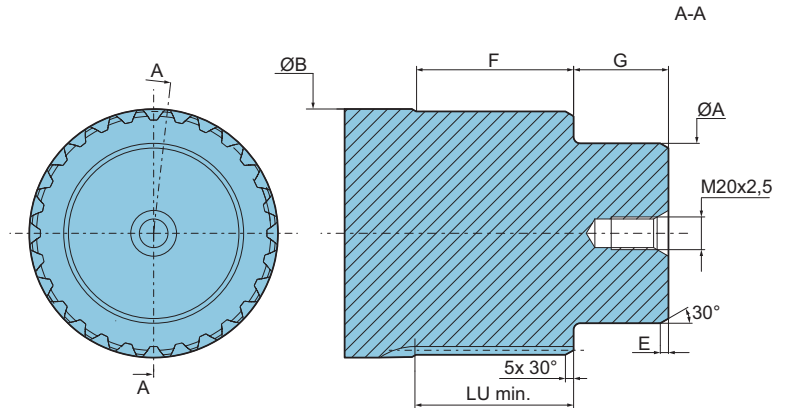

For torque arm mounting, both motor and customer shafts must be in axial contact (no axial play) + must have sealing between motor and customer shafts.



For chassis mounting, an axial play must be ensured between motor and customer shafts.



Consult your Poclain Hydraulics application engineer.



VALVING SYSTEMS AND HYDROBASES

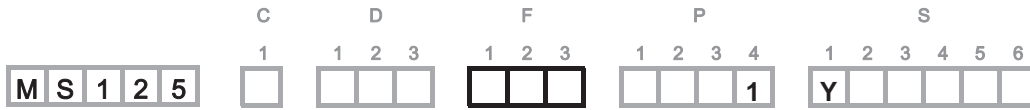

Dimensions for 1-displacement valving

	301 kg [662 lb]	399 kg [878 lb]
	4,50 L [270 cu.in]	4,00 L [240 cu.in]

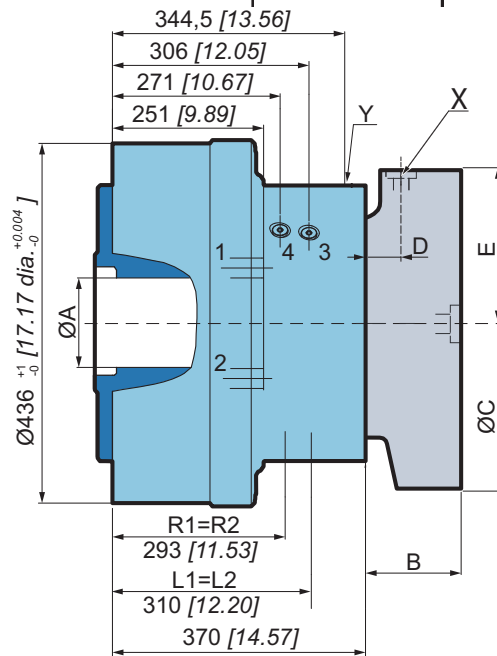
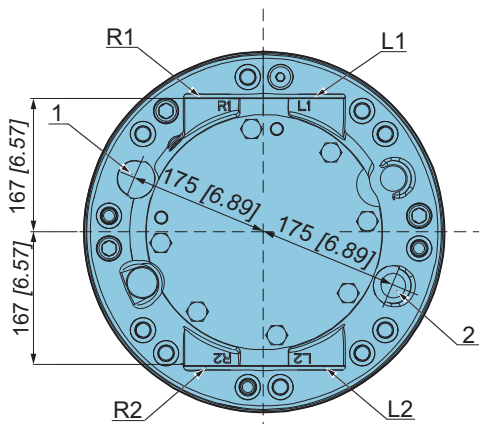

	T 8 0
B	189,0 [7,44]
C	Ø376 [14,80 dia.]
D	44,0 [1,73]
E	181,0 [7,13]

Also see "Brake" section (thumbnail opposite).

Cylinder block splines

Standard	ØA	Module	Z	Y	ØV	
DIN 5480	130 [5,118]	3	42	119,078 [4,688]	5,25 [0,207]	1

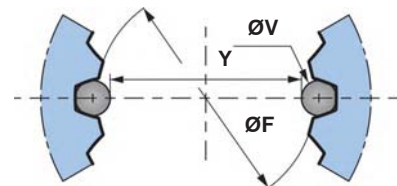

You are advised to have the installation validated by your Poclair Hydraulics application engineer before using the hydraulic unit in an application.



We must provide you with a detailed plan of the interface for any hydraulic unit use, consult your Poclair Hydraulics sales engineer.

Modularity and Model code

Wheel motor

Shaft motor

Valving systems and hydrobases

Brake

Options



Dimensions for 2-displacement symmetrical valving

For a small displacement, there is no preferred orientation for this motor.

	301 kg [662 lb]	399 kg [878 lb]
	4,50 L [270 cu.in]	4,00 L [240 cu.in]

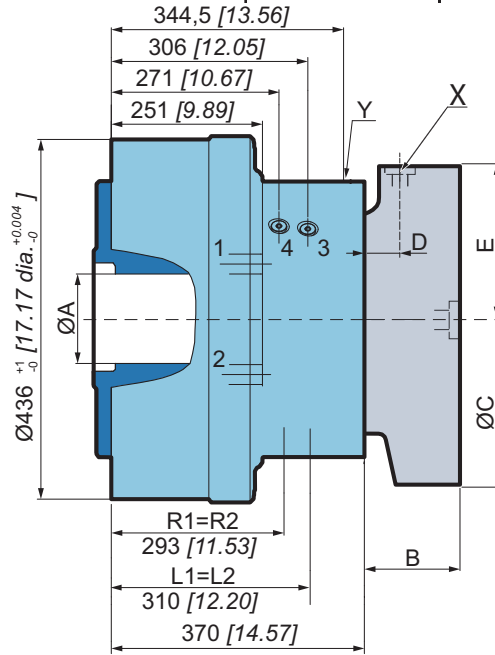
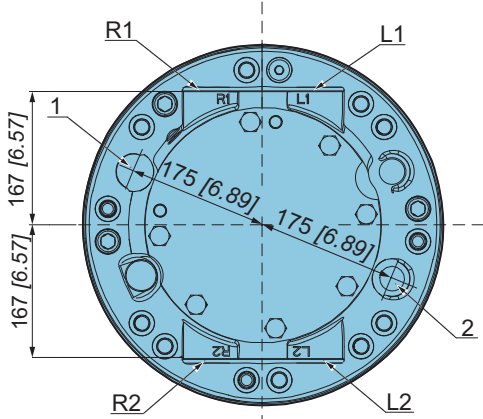

	C	T 8 0
B	189,0 [7,44]	
C	Ø376 [14,80 dia.]	
D	44,0 [1,73]	
E	181,0 [7,13]	



Also see "Brake" section (thumbnail opposite).

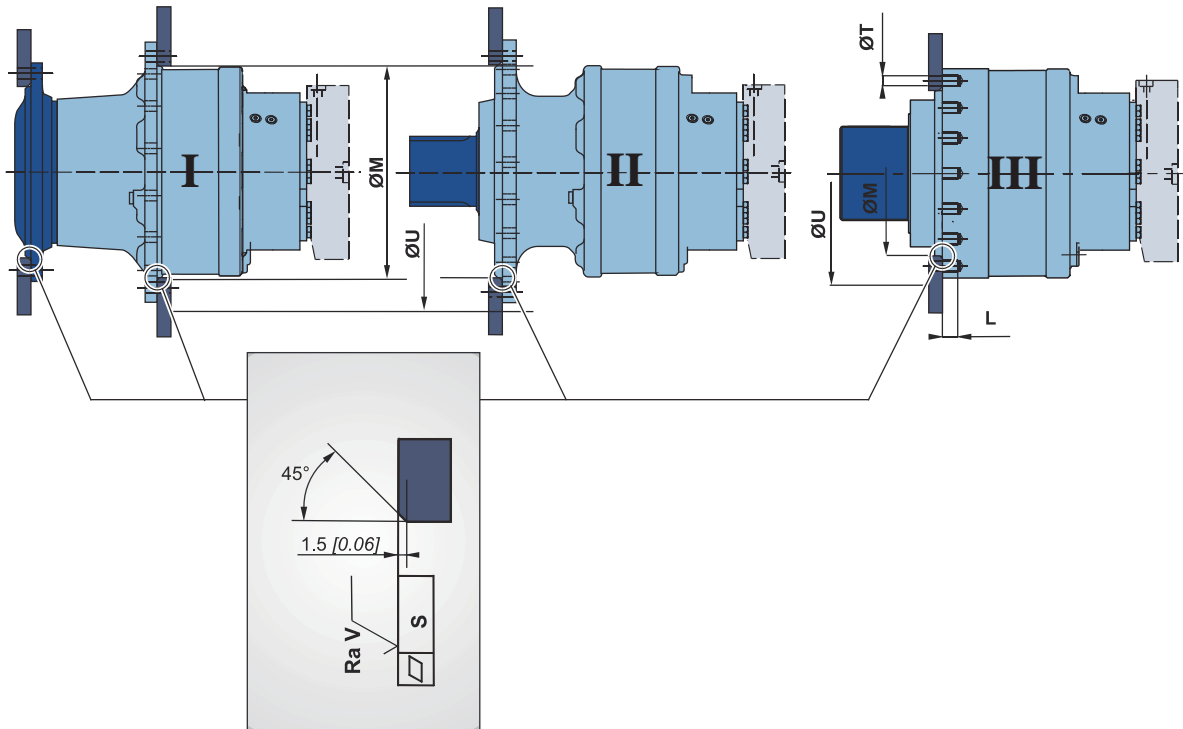

Chassis mountings



Take care over the immediate environment of the connections.

	$\varnothing M$ ⁽¹⁾ mm [in]	$\varnothing U$ mm [in]	$\varnothing T$ mm [in]	L mm [in]	S mm [in]	Ra V μm [μin]		Class	 * N.m [lb.ft]
I	450 [17,72]	565 [22,24]	-	-	0,2 [0,008]	12,5 [0,49]	16 x M24	12,9	1 200 [885,1]
II							20 x M24		
III	352 [13,86]	446 [17,56]	25,5 [1,004]	35 [1,378]	16 x M20				

(1) +0,3 [+0,012]
+0,2 [+0,008]

* : Min. values for torque and load to be transmitted.

Modularity and Model code

Wheel motor

Shaft motor

Valving systems and hydrobases

Brake

Options



Hydraulic connections

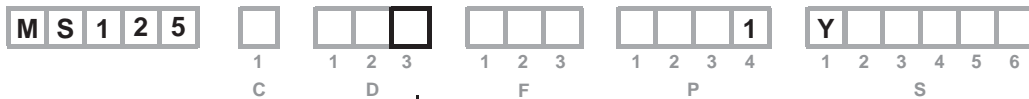
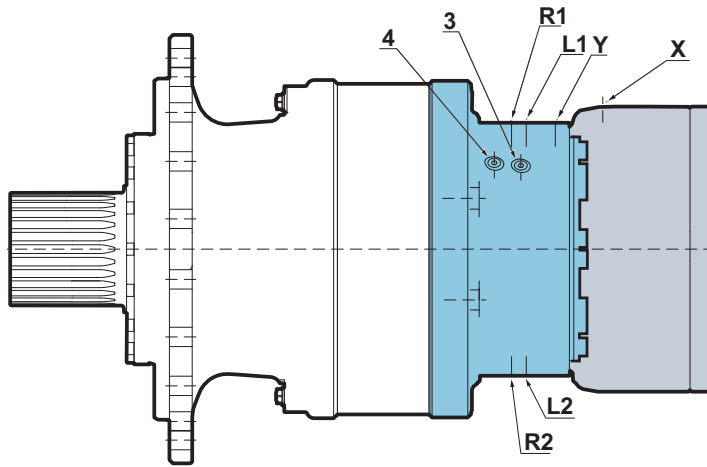

		Standards	Power supply	Case drain	2 nd displacement control	Pressure measurement points	Control of parking break
			R-L	1, 2		3, 4	X
	J	Metric	DN32 PN400	M27x2 Ø27		M14x1.5 Ø13	M18x1.5 Ø17
	K	Gaz (BSPP)					
		ISO 9974-1 ISO 1179-1	R-A	1, 2	Y	3, 4	X
	J	Metric	DN32 PN400	M27x2 Ø27	M18x1.5 Ø17	M14x1.5 Ø13	M18x1.5 Ø17
	K	Gaz (BSPP)					
		ISO 9974-1 ISO 1179-1					
Max. pressures		MS bar [PSI]	450 [6 527]	1 [15]	30 [435]	30 [435]	30 [435]



You are strongly advised to use the fluids specified in brochure "Installation guide" N° 801478197L.



To find the connections' tightening torques, see the brochure "Installation guide" N° 801478197L.

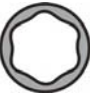

Efficiency

Overall efficiency

Average values given for guidance for code 0 displacement after 100 hours of operation with HV46 hydraulic fluid at 50°C [122°F].

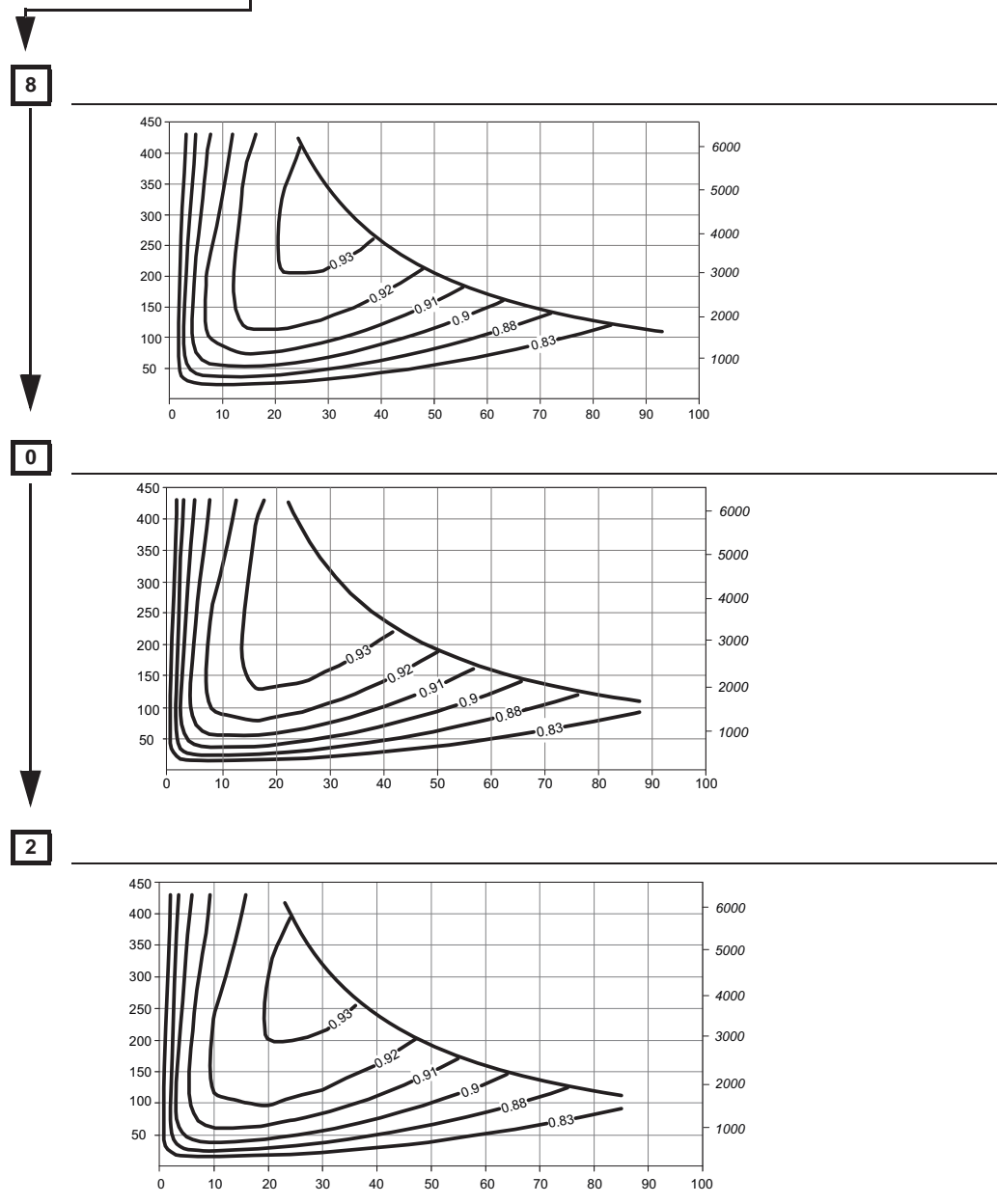
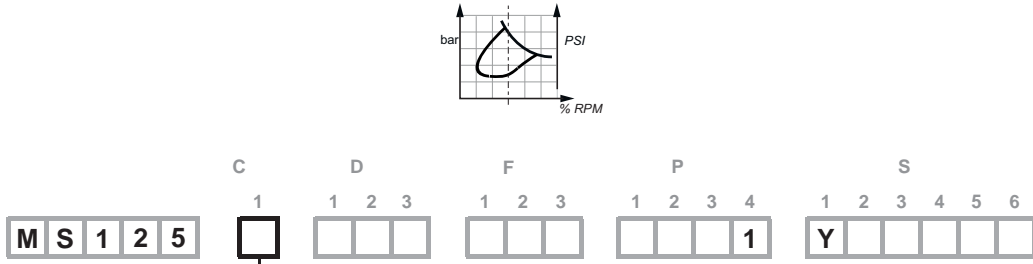

For a precise calculation, consult your Poclain Hydraulics application engineer.

Modularity and Model code

Wheel motor

Shaft motor

Valving systems and hydrobases

Brake

Options



Pressure drop and charge pressure

Pressure drop (With HV46 hydraulic fluid at 50 °C [122 °F], oil viscosity 30 cSt)

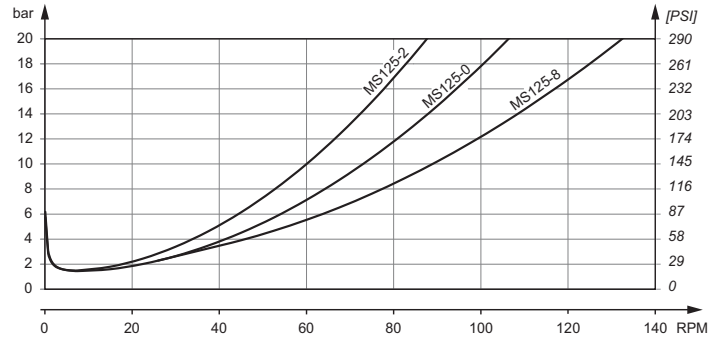

Charge pressure (With HV46 hydraulic fluid at 50 °C [122 °F], oil viscosity 30 cSt)

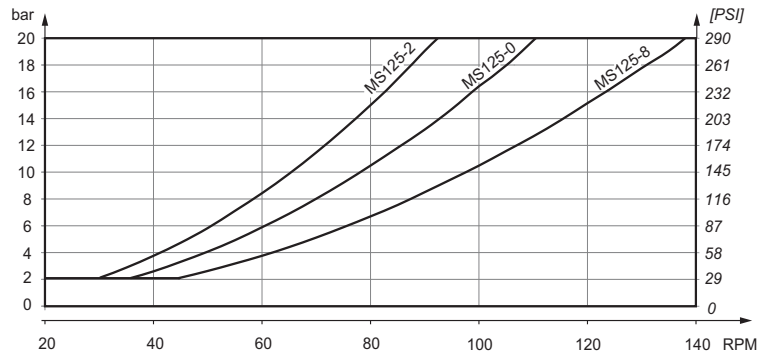

Pressure drop and charge pressure curves are corresponding to 1st displacement motor.



BRAKES

Rear brake

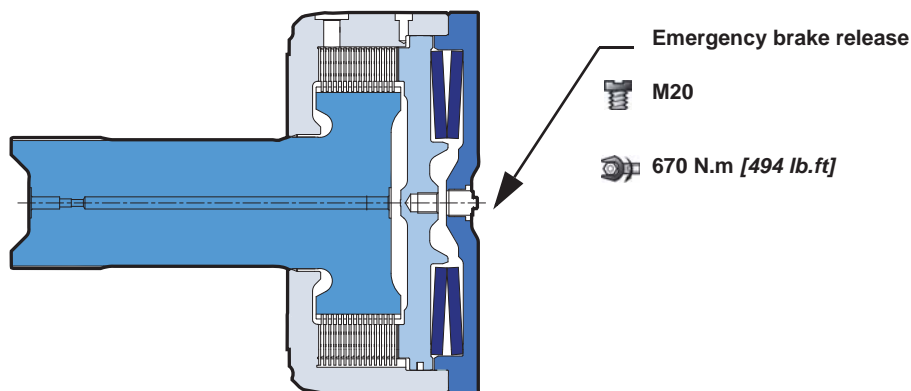
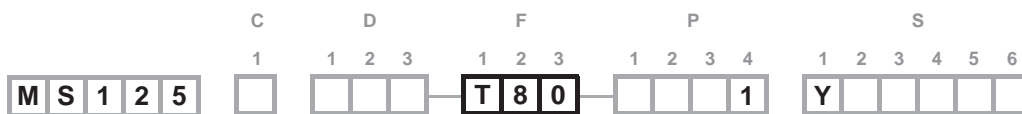

Brake principle

This is a multidisc brake which functions through the absence of pressure. The spring exerts a force on the piston, which acts on the fixed and mobile discs, and thus immobilizes the shaft. The braking torque decreases in linear proportion to the brake release pressure.

C	T 8 0
Parking brake torque at 0 bars on housing (new brake)	72 000 Nm [53 100 lb.ft]
Dynamic emergency braking torque at 0 bars on housing (max. 10 uses of emergency brakes)	62 400 Nm [46 020 lb.ft]
Residual parking braking at 0 bars on housing *	54 000 Nm [39 830 lb.ft]
Min. brake release pressure	20 bar [290 PSI]
Max. brake release pressure	30 bar [435 PSI]
Oil capacity	450 cm ³ [27,5 cu.in]
Volume for brake release	135 cm ³ [8,2 cu.in]
Min. internal irrigation flow rate (at 20 bar brake release pressure)	1,7 L/min [0,45 gal/min]
Max. internal irrigation flow rate (at 30 bar brake release pressure)	3,1 L/min [0,82 gal/min]

* After emergency brake has been used

- Do not run-in the multidisc brakes.
- A functional check of the parking brake must be carried out each time it is used as an auxiliary brake (or emergency brake). For all vehicles capable of speeds over 25 km/hour, please contact your Poclain Hydraulics application engineer.
- This negative brake can be used as dynamic braking under specific conditions (depends on duty cycle). In case of dynamic use, please contact your Poclain Hydraulics application engineer.

Modularity and Model code

Wheel motor

Shaft motor

Valving systems and hydrobases

Brake

Options





OPTIONS

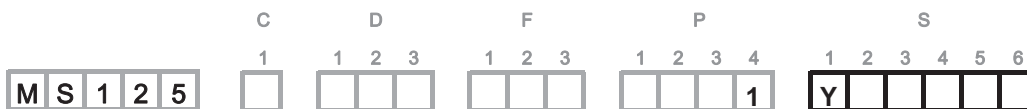

You can accumulate more than one optional part. Consult your Poclain Hydraulics sales engineer.

Y - Standard option

Designation



Predisposal for speed sensor	
Additional drain on valving system	
High speed/Low pressure drop (Butterfly valving)	Y
Grip washer (when using T80)	

2 - S - Q Installed speed sensor

Designation



T4 Speed sensor (without rotation direction)	2
TR Speed sensor (digital rotation direction)	S
TD speed sensor (two phase shifted frequencies)	Q

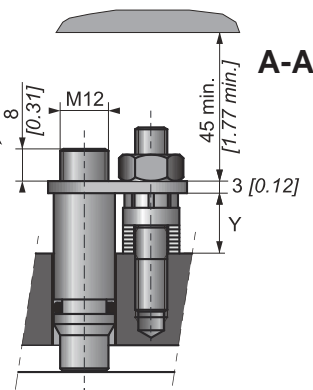
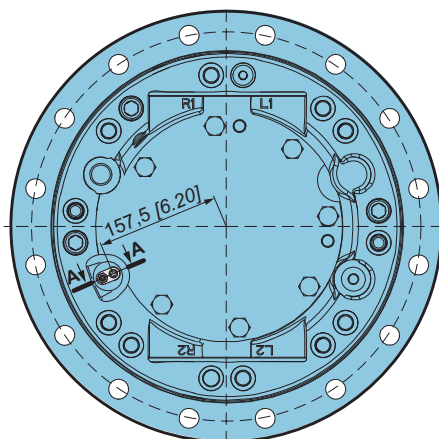

Max. length Y= 14.8
Standard number of pulses per revolution= 60



Look at the "Mobile Electronic" N° A01889D technical catalogue for the sensor specifications and its connection.



To install the sensor, see the "Installation guide" brochure No. 801478197L.

Modularity and Model code

Wheel motor

Shaft motor

Valving systems and hydrobases

Brake

Options



6 - Industrial support

Reduction of around 50% from the rated value in the bearings' preload value.



For a precise calculation, consult your Poclain Hydraulics application engineer.

7 - Diamond™

Special treatment of the motor core which considerably increases its strength, making the motor much more tolerant to temporary instances of the operating conditions being exceeded.

A - Hollow shaft

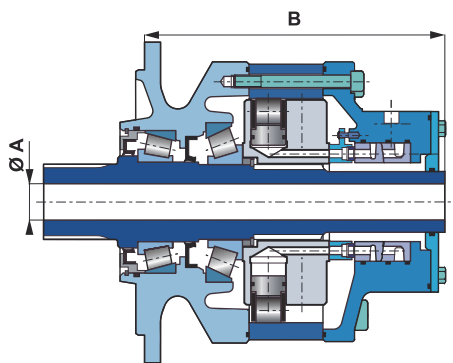

A	B
mm [in]	mm [in]
Ø 75 [2,95 dia.]	634 [24,97]

Radial load x 0.75
No torque transmittable to the rear

B - Drain on the bearing support

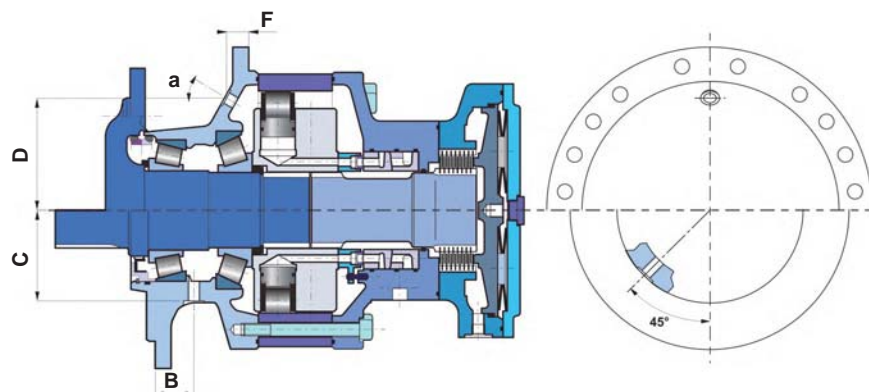

	B	C	D	F	a
	mm [in]	mm [in]	mm [in]	mm [in]	
Shaft motor	-	-	173 [6,81]	40 [1,57]	36°
Wheel motor	70 [2,76]	185 [7,28]	-	-	-

D - Special paint or no paint

The motors are delivered with Poclain Hydraulics yellow ochre primer as standard.



Consult your Poclain Hydraulics application engineer for other colors of primer or topcoat.



E - Reinforced sealing

Requires reinforced seals and, for an unbraked motor, a rear reinforced plate (R83 - 15 [0.594] thick, instead of 6 [0.237]).

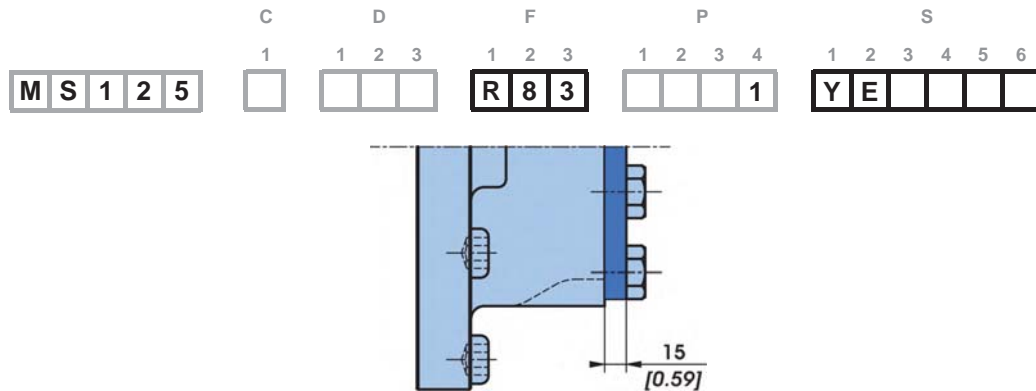

G - Special wheel rim mounting

Enables certain combinations different from the standard mountings defined on page 10.



Consult your Poclain Hydraulics sales engineer.

J - Treated shaft

Heat treatment on the indicated bearing radius and splines.

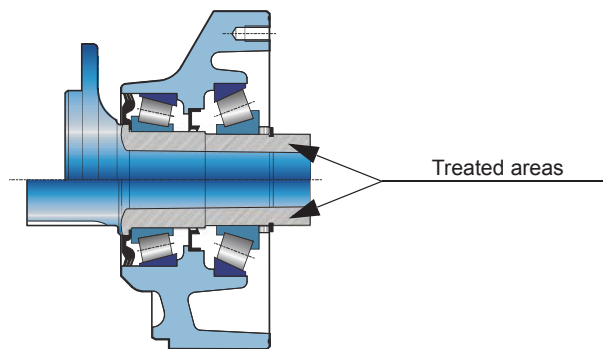

Modularity and Model code

Wheel motor

Shaft motor

Valving systems and hydrobases

Brake

Options



Poclain Hydraulics reserves the right to make any modifications it deems necessary to the products described in this document without prior notification. The information contained in this document must be confirmed by Poclain Hydraulics before any order is submitted.

Illustrations are not binding.

The Poclain Hydraulics brand is the property of Poclain Hydraulics S.A.

-  27/02/2017
-  801 478 126J
-  801 478 196K
-  801 578 109L
-  801 578 121Z
-  801 578 133M
-  A50155R
-  Not available
-  A14248M

